

INSTRUCTION MANUAL



IGT8
www.igt8.com

HIGH PERFORMANCE RC

B8e₂₀₂₁
Electric Buggy

For any additional questions, please send us an email to: info@igt8.com

OVERVIEW

Components



IGT8 Stickers



Parts Bag

TOOLS NOT INCLUDED IN THE KIT



Body Reamer



Screw Cement



Instant Cement



Curved Scissors



Cutter



Gear Grease



Needle Nosed Pliers



Craft Knife



Precision Caliper

Equipment Needed



Transmitter



Servo



Sped Control



Brushless Motor



Receiver



7.4V Li-Po Battery (hard case)



Li-Po Battery Charger

1 ASSEMBLY OF THE FRONT AND REAR DIFF.

BAG 1

Build two differentials for front and rear.

Step 1

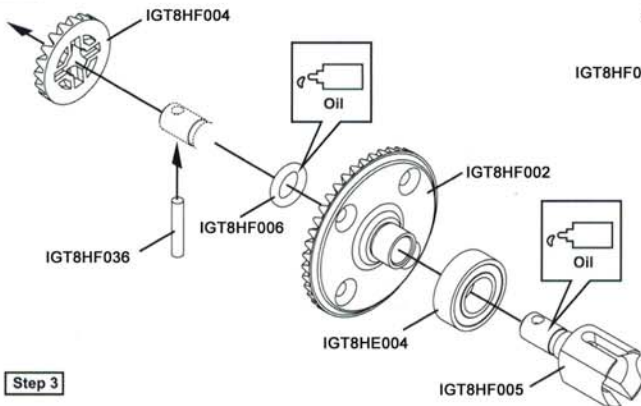

Step 2

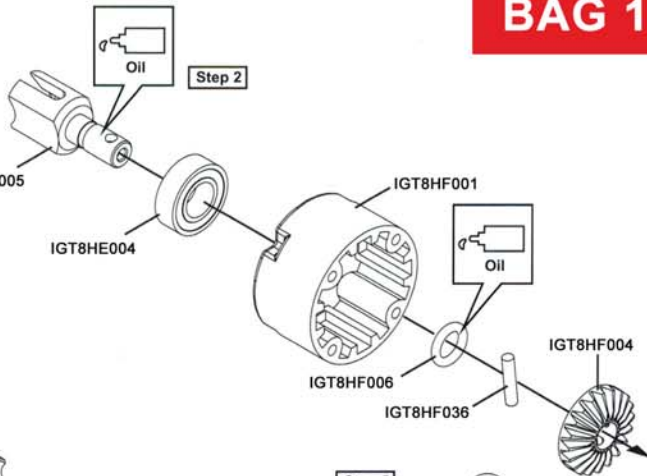

Step 3

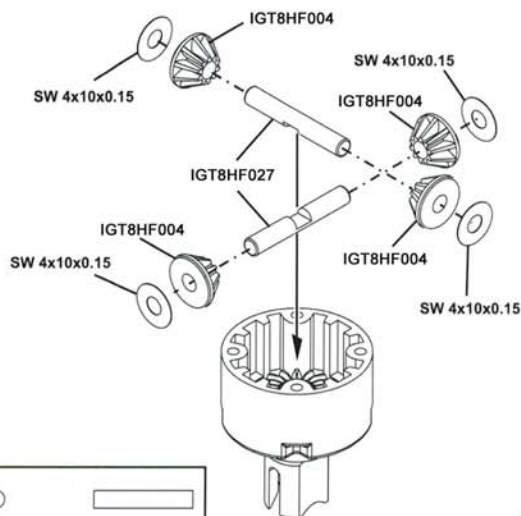

Step 4



Step 5

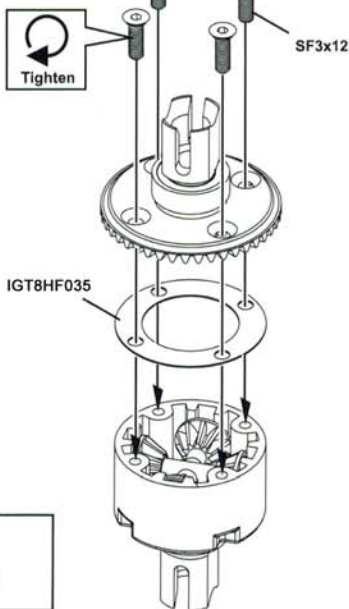

- Use diff oil 7,000 for front and 3,000 for rear.
- Use White Oil pen mark front diff. case and rear diff. case.

	IGT8HF036 2.5x11.8mm Pinx4
	IGT8HF006 P6 O-Ringx4
	IGT8HE004 8x16x5mm Ball Bearingx4
	SW 4x10x0.15 4x10x0.15mm Washerx8
	IGT8HF027 4mm Cross Pinx4
	SF3x12mm Flat Head Hex Screwx8

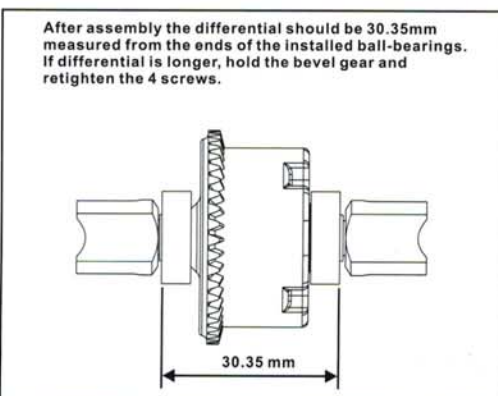
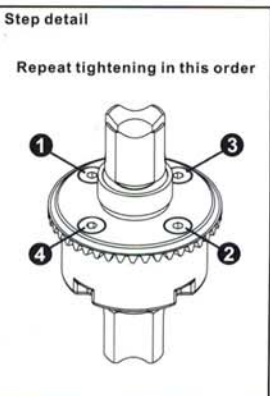
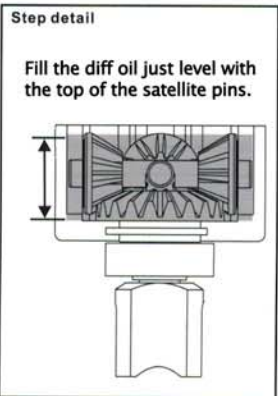
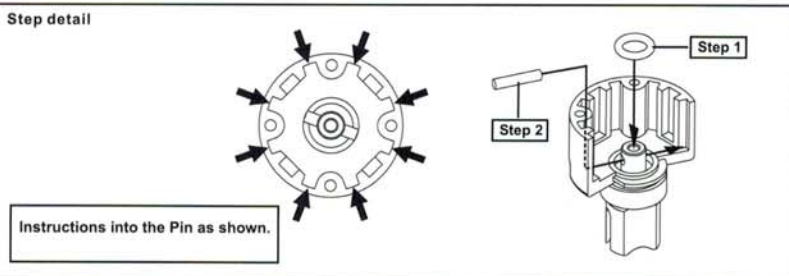
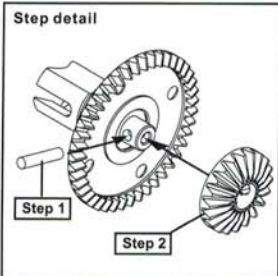

Step 1

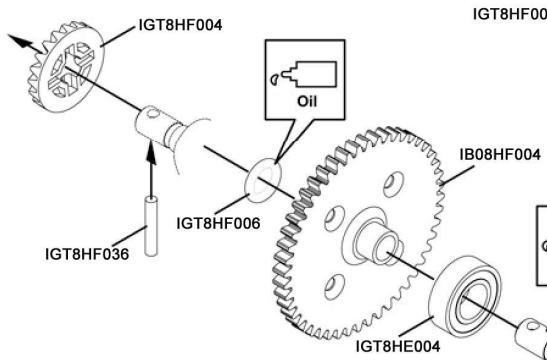

Step 2

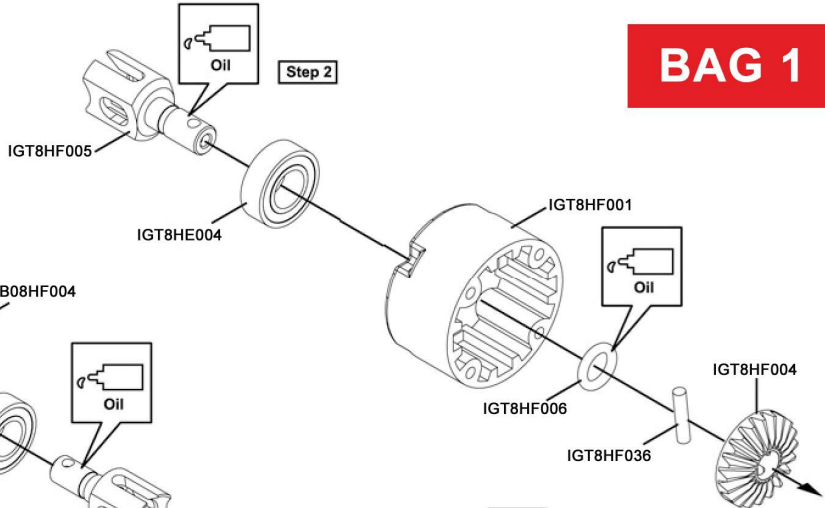

Step 3

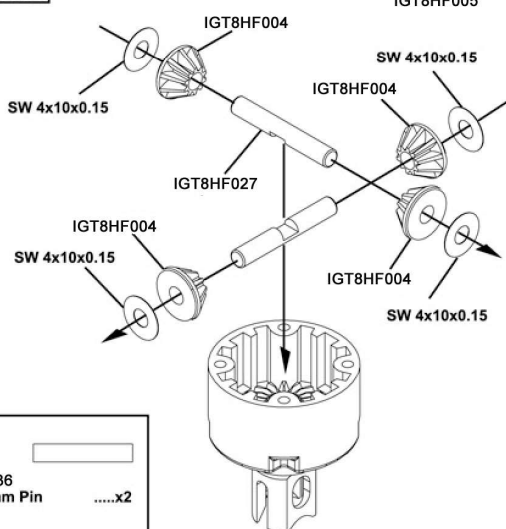



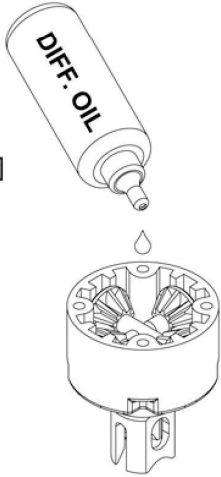

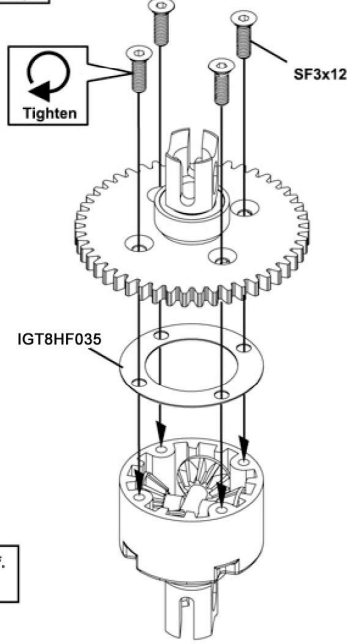

Step 4



Step 5



Use the Diff. Oil #5000 for the center diff.

-  IGT8HF036
2.5x11.8mm Pinx2
-  IGT8HF006
P6 O-Ringx2
-  IGT8HE004
8x16x5mm
Ball Bearingx2
-  SW 4x10x0.15
4x10x0.15mm
Washerx4
-  IGT8HF027
4mm Alum. Cross Pinx2
-  SF3x12mm
Flat Head Hex Screwx4

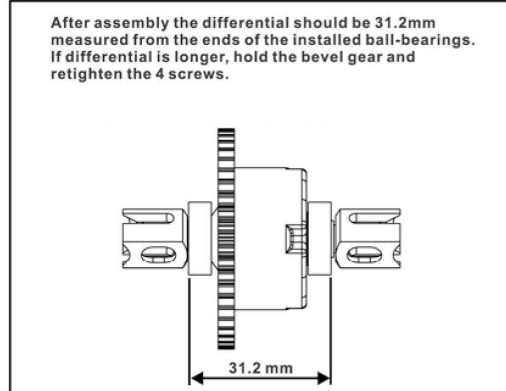
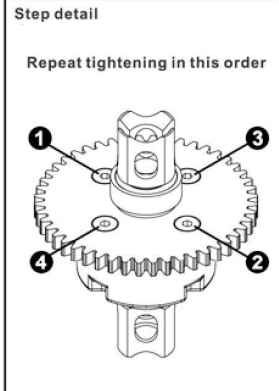
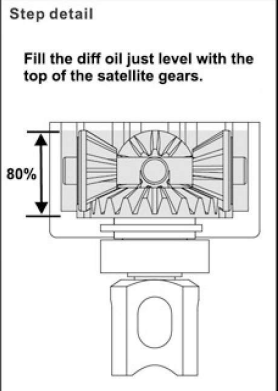
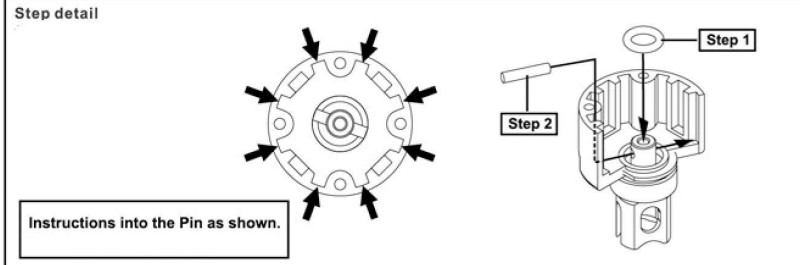
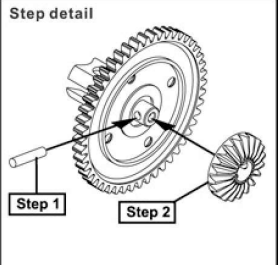
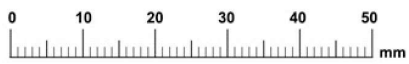



4 ASSEMBLY OF THE FRONT GEAR CASE

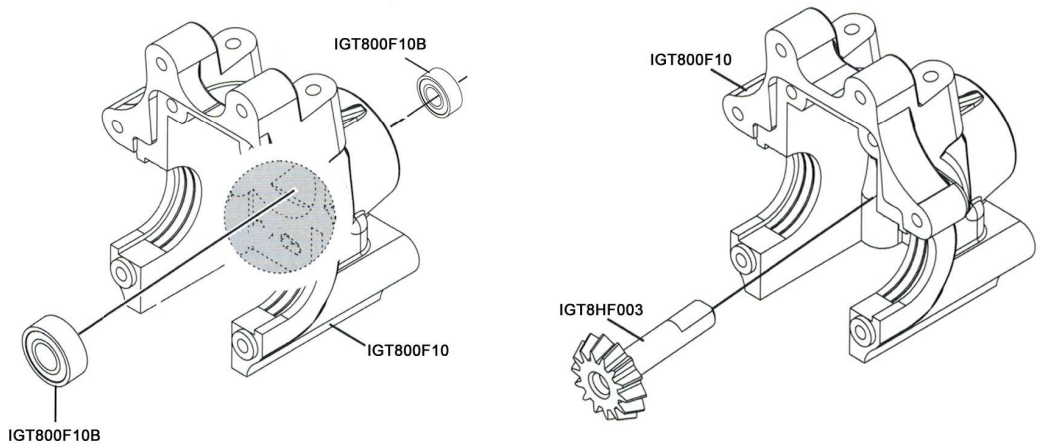
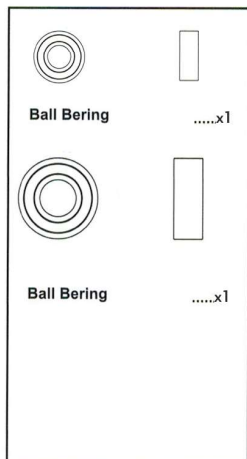

BAG 2

5 ASSEMBLY OF THE FRONT DIFFERENTIAL INTO GEAR CASE

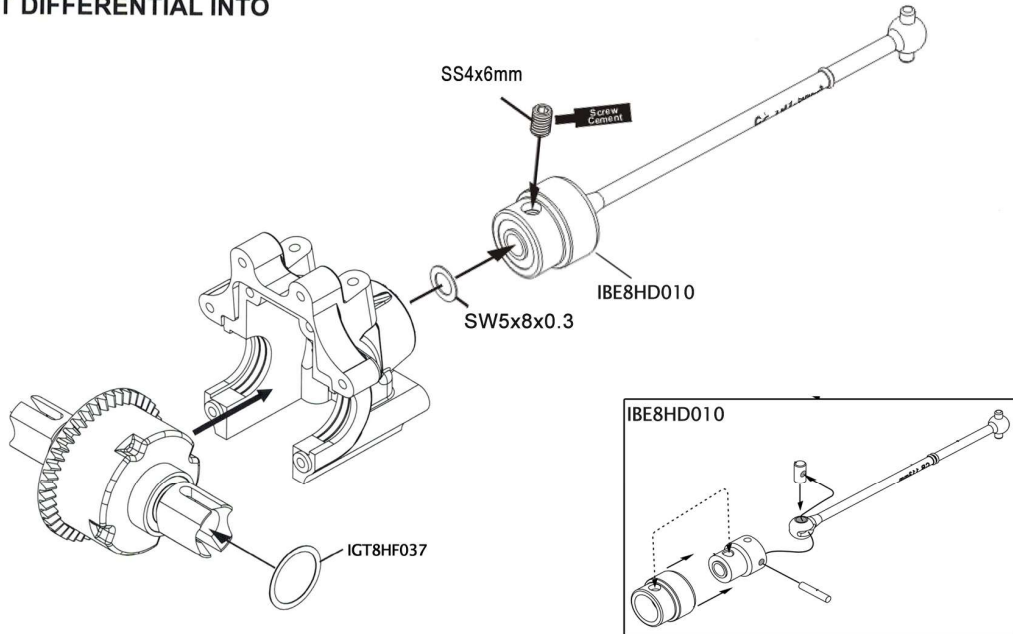
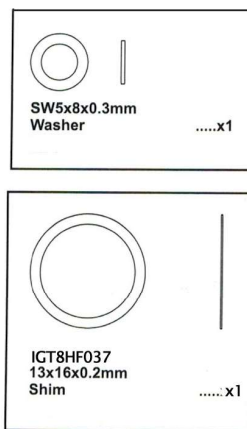

6 ASSEMBLY OF THE FRONT DIFFERENTIAL INTO GEAR CASE

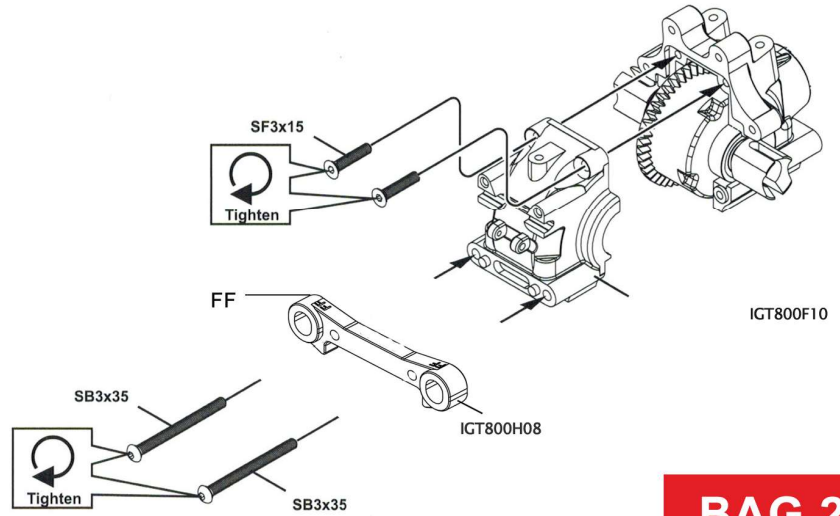
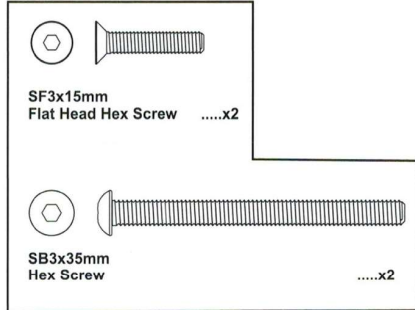

BAG 2

7 ASSEMBLY OF THE FRONT SHOCK STAY

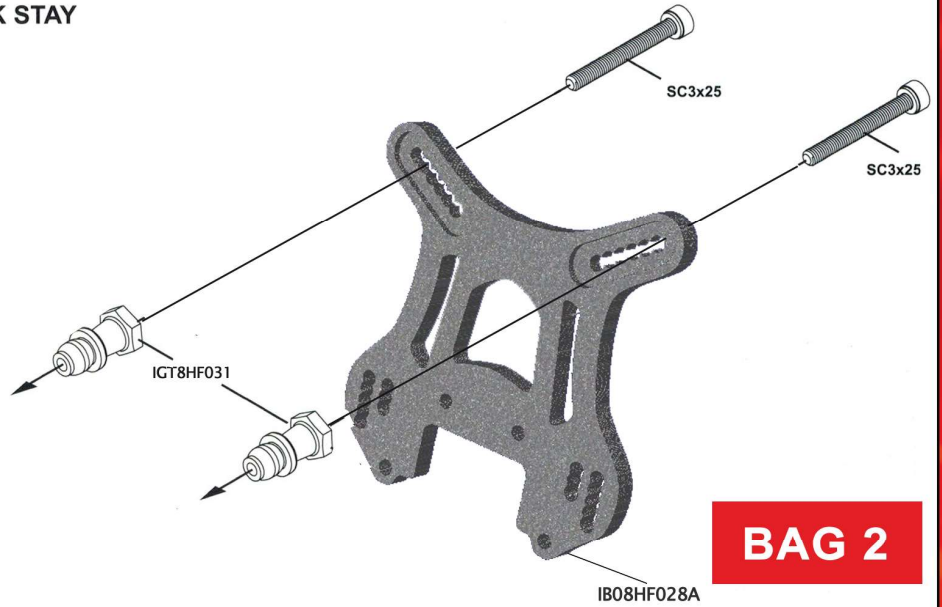
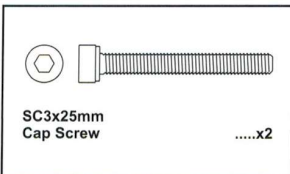

BAG 2

8 ASSEMBLY OF THE FRONT SHOCK STAY ONTO GEAR CASE

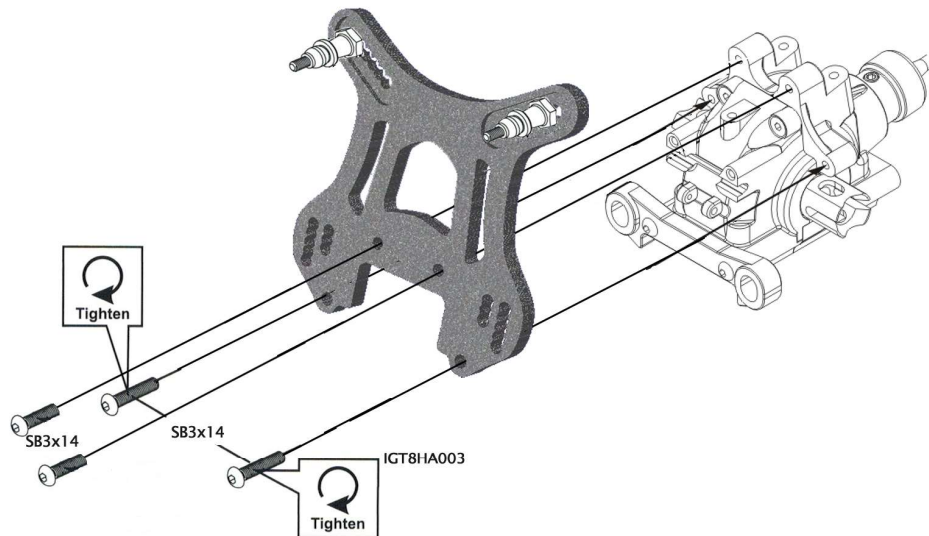
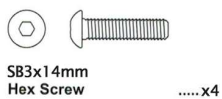

9 ASSEMBLY OF THE FRONT LOWER ARMS

Assemble both right and left sides.

Step detail

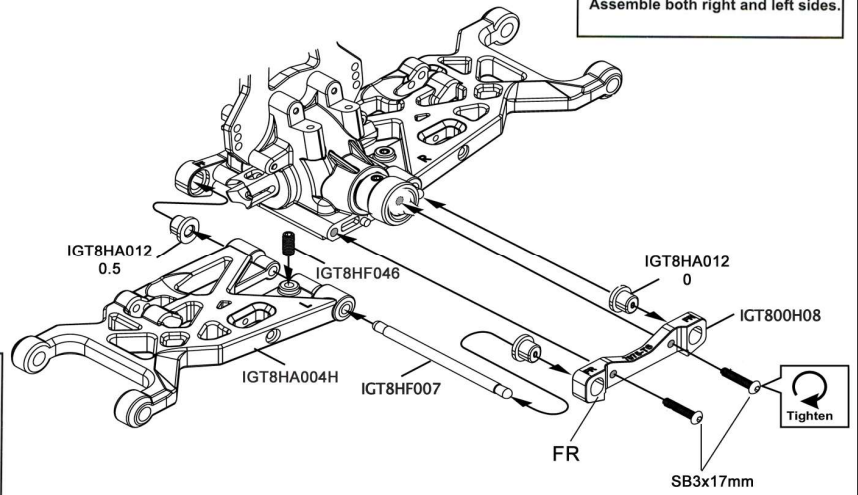
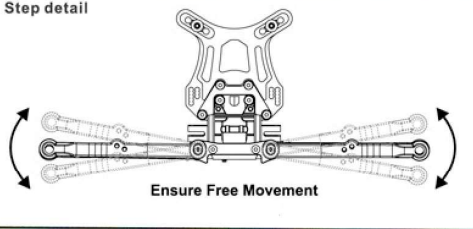

BAG 2



11 ASSEMBLY OF THE FRONT STABILIZER ROD

BAG 2

Step detail

Ensure Free Movement

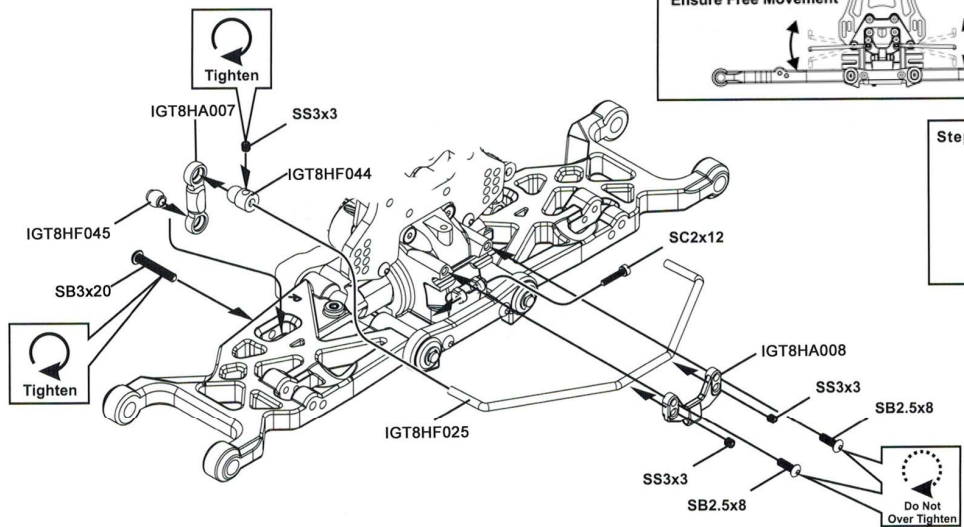
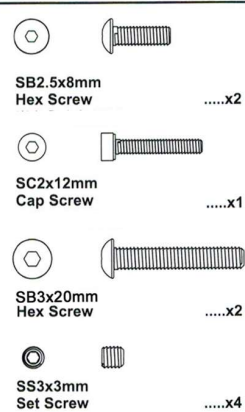
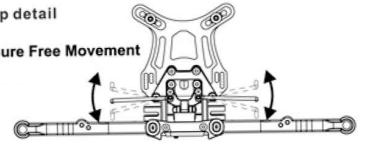

Step detail

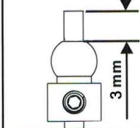

12 ASSEMBLY OF THE FRONT KNUCKLE ARMS

BAG 2

- IGT8HE001 13x20x4mm Ball Bearingx2
- IGT8HE006 8x14x4mm Ball Bearingx2
- SS3x6mm Set Screwx4
- 3xmm Nylon Nutx2

LEFT SIDE

Step 1

Step 2

Step 3

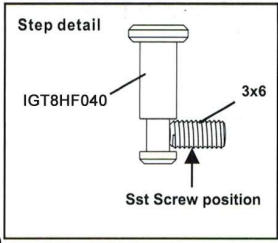

IGT800F38
Note.- Kit comes with caster block insert #4 (10° and 18°)

- Optional Caster Block Inserts #
- IGT800F340 - Caster Block Insert #0 (14°)
 - IGT800F341 - Caster Block Insert #1 (13°/15°)
 - IGT800F342 - Caster Block Insert #2 (12°/16°)
 - IGT800F346 - Caster Block Insert #6 (8°/20°)
 - IGT800F348 - Caster Block Insert #8 (6°/22°)

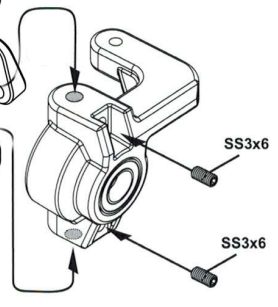

Assemble both right and left sides.

13 ASSEMBLY OF THE FRONT CVD INTO KNUCKLE ARMS

BAG 2

- LEFT SIDE
- Assemble both right and left side.
- IGT8HF070 2.5x12.8mm Pinx2
 - IGT8HF039 2.5x16.8mm Pinx2
 - SS4x4mm Set Screwx2

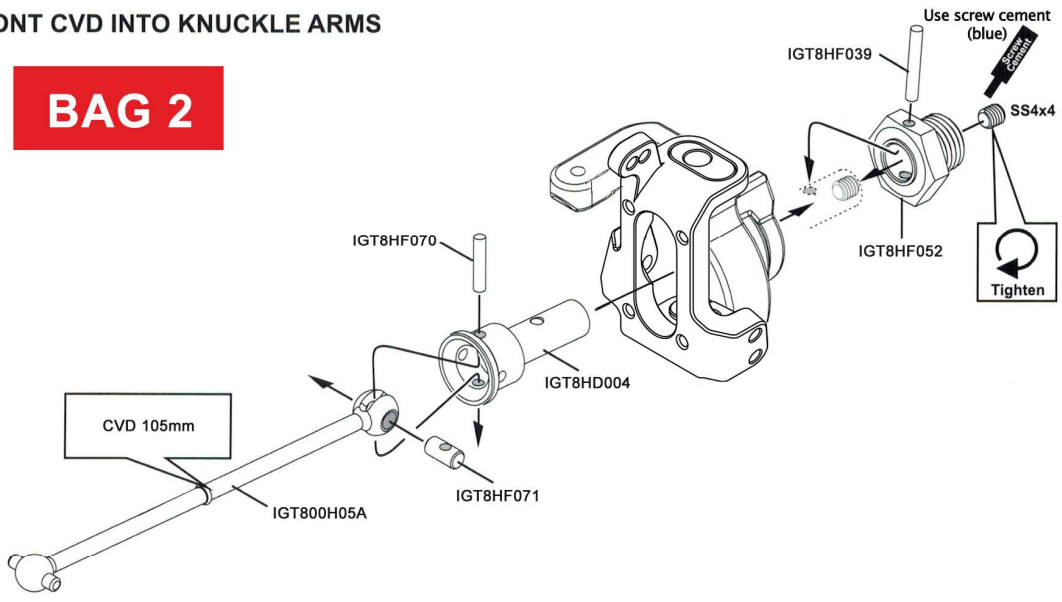

14 ASSEMBLY OF THE KNUCKLE ARMS ONTO FRONT LOWER ARMS

Assemble both right and left sides.

*Insert the front drive shaft into cap joint before assembly.

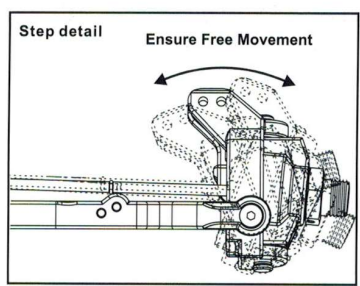

- SB4x14mm Hex Screwx4

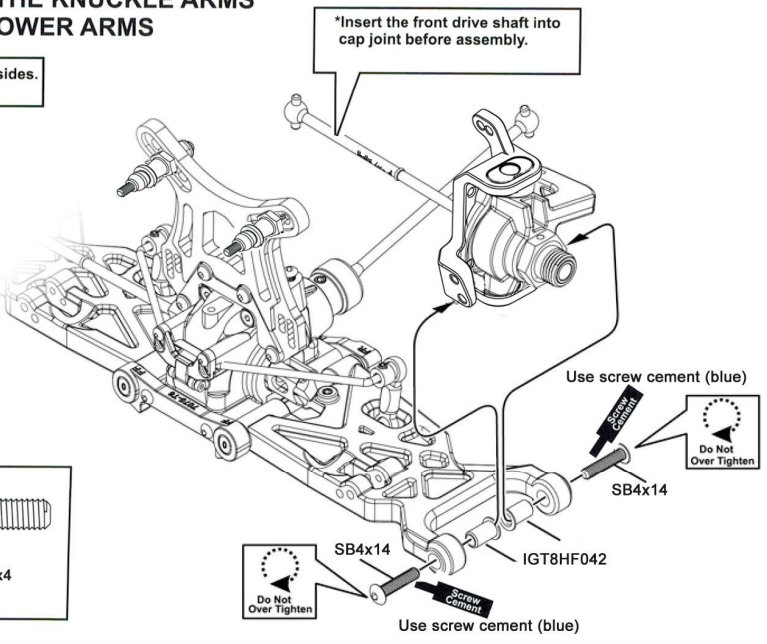



15 ASSEMBLY OF THE FRONT UPPER ARMS

BAG 2

Assemble both left and right sides.

LEFT SIDE

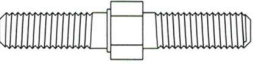

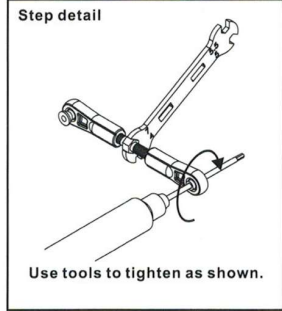
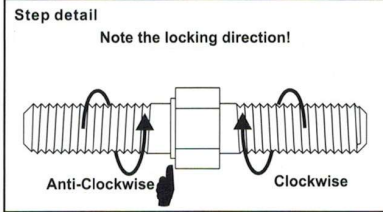
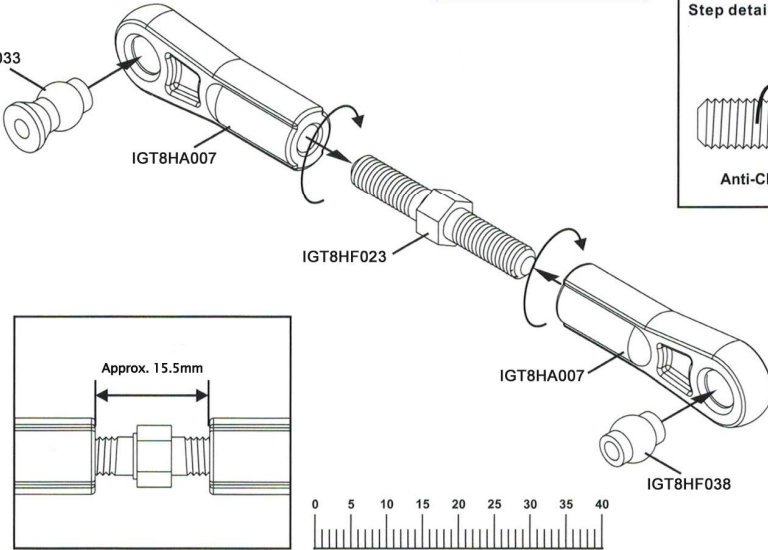
-  IGT8HF033 7x12mm Ballx2
-  IGT8HF038 7mm Ballx2
-  IGT8HF023 5x35mm Turnbucklex2



16 ASSEMBLY OF THE FRONT UPPER ARMS

Assemble both right and left sides.

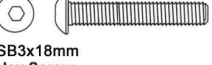

LEFT SIDE

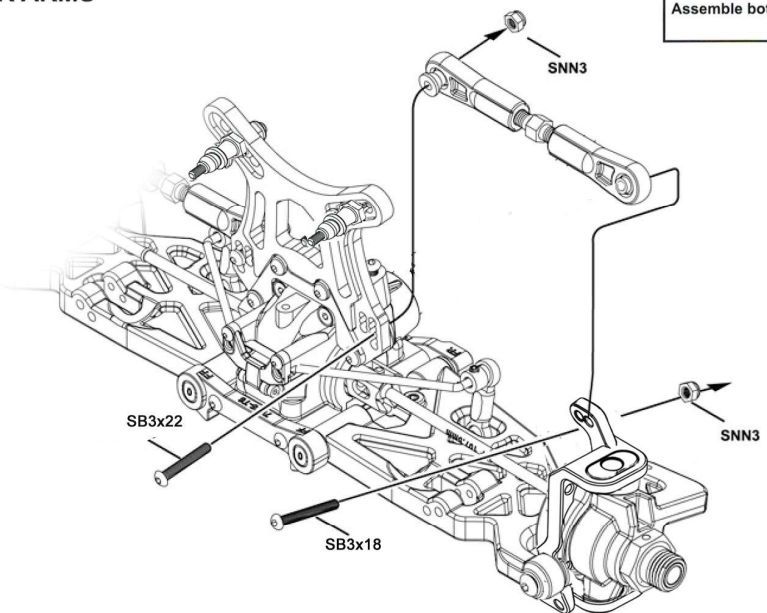
-  SNN3mm Nylon Nutx4
-  SB3x18mm Hex Screwx2
-  SB3x22mm Hex Screwx2

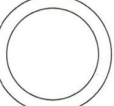

17 ASSEMBLY OF THE SERVO SAVER

BAG 3

-  IGT8HF029 Steering Plat Hex Screwx2
-  IGT800H10 12x1.7mm O-Ringx1
-  SNN3mm Nylon Nutx3
-  SW4x8x0.25 Washerx2

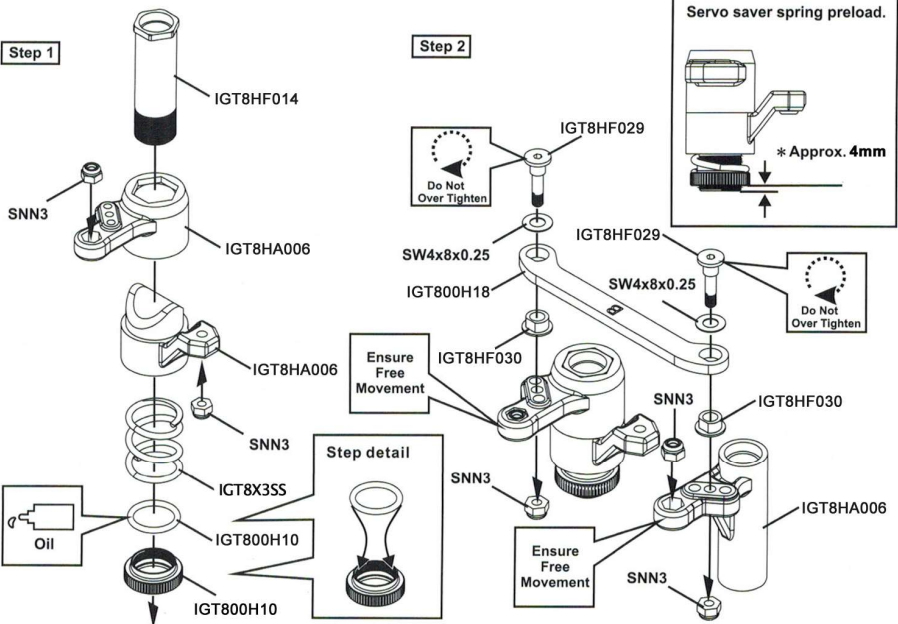

18 ASSEMBLY OF THE FRONT PLATE ONTO SERVO SAVER

- SNN3mm Nylon Nutx1
- SB3x10mm Hex Screwx3
- SW3x6x0.5 Washerx2

BAG 3

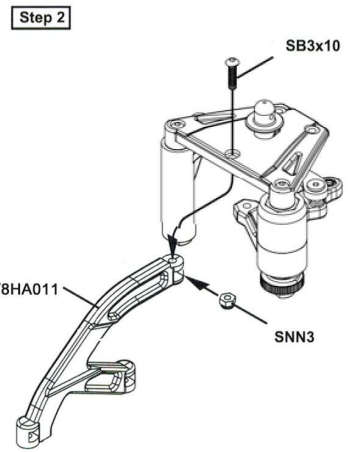
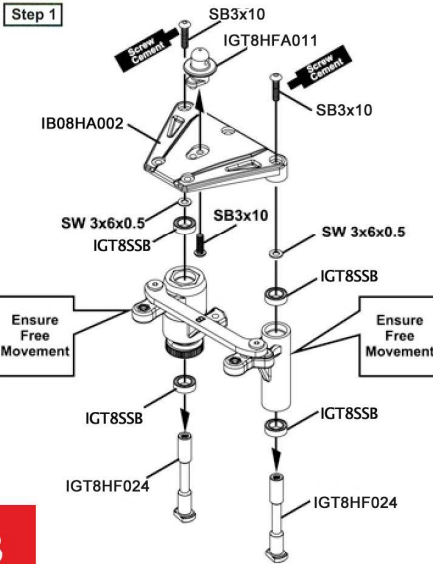

19 ASSEMBLY OF THE STEERING TIE-ROD

Make two steering rods for left and right hand sides.

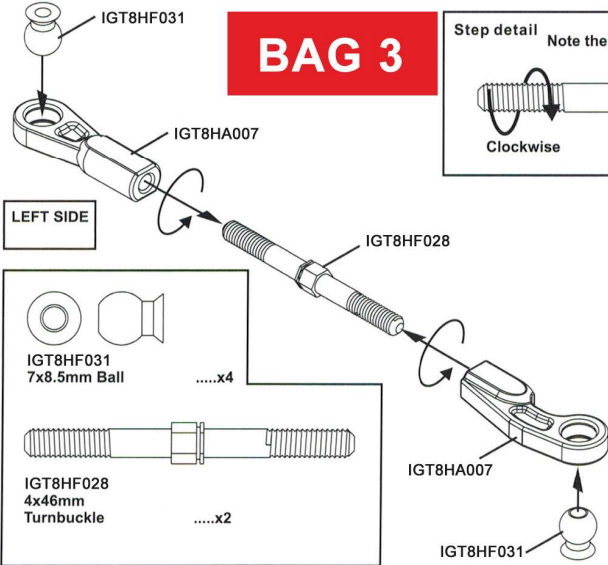

- IGT8HF031 7x8.5mm Ballx4
- IGT8HF028 4x46mm Turnbucklex2

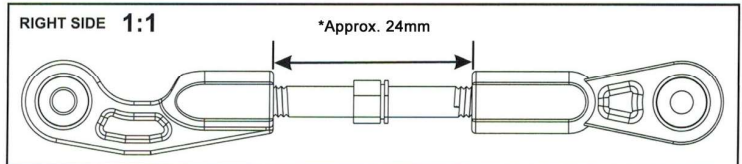
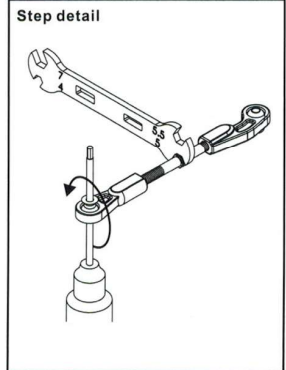
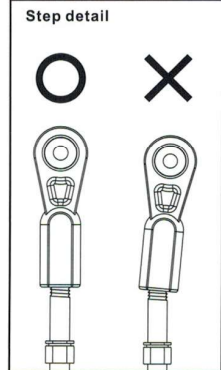
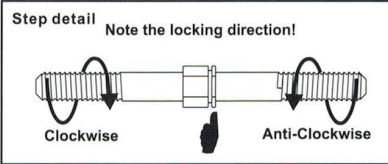

20 ASSEMBLY OF THE STEERING TIE-ROD

BAG 3

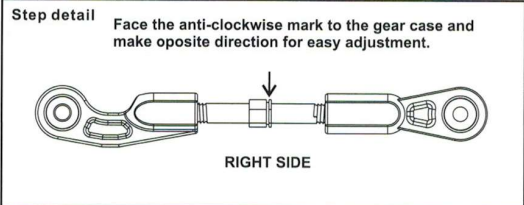

- SF3x16mm Flat Head Hex Screwx2

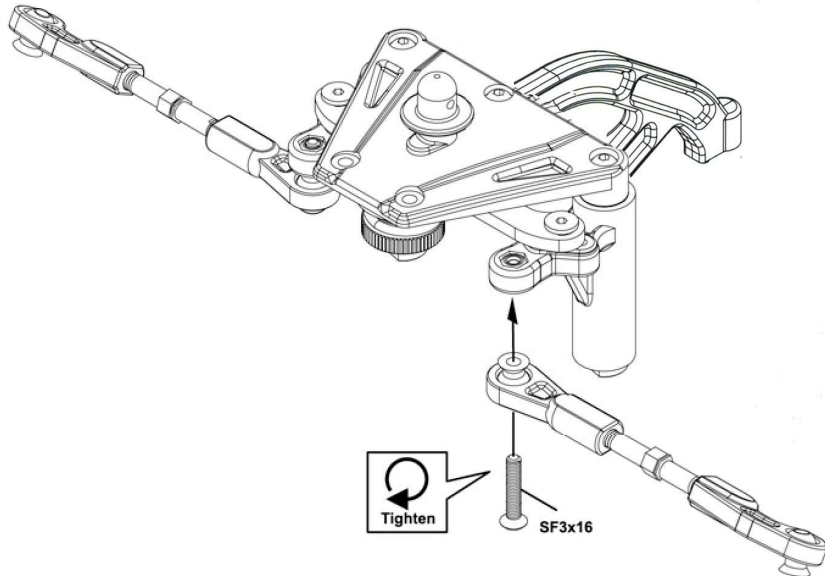

21 ASSEMBLY OF THE SERVO SAVE R ONTO THE FRONT GEAR BOX

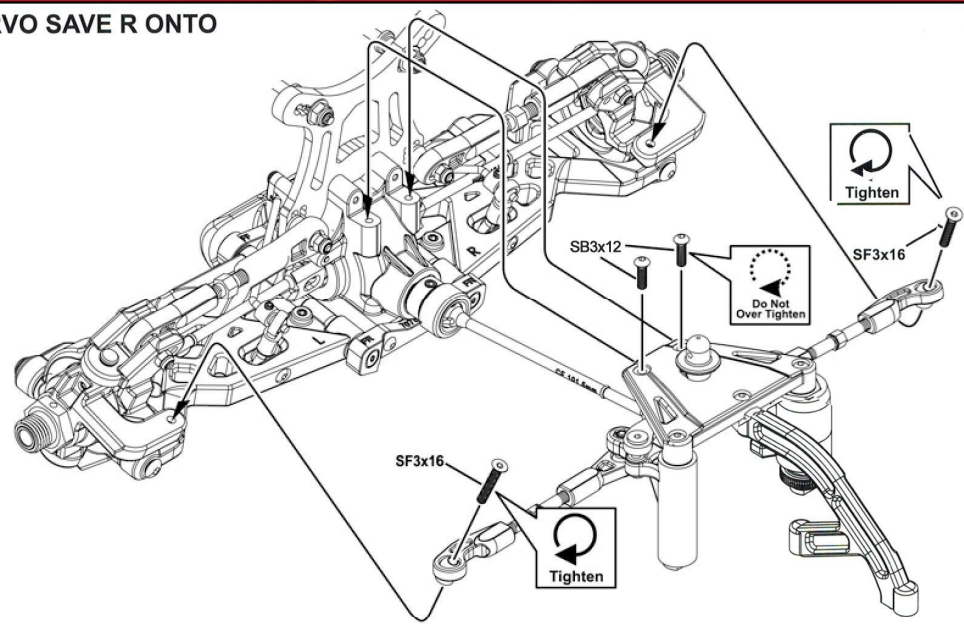

- | | | |
|--|------------------------------|---------|
| | SF3x16mm Flat Head Hex Screw |x2 |
| | SB3x12mm Hex Screw |x2 |

22 ASSEMBLY OF THE REAR GEAR CASE

BAG 4

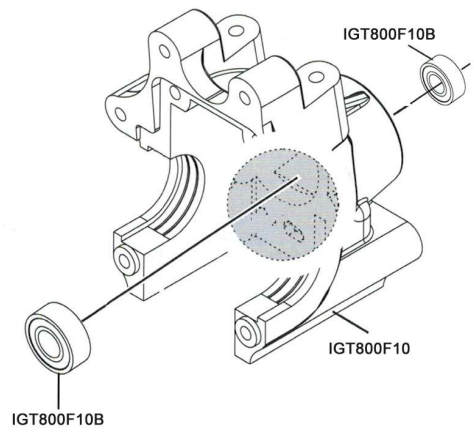

- | | | |
|--|--------------|---------|
| | Ball Bearing |x1 |
| | Ball Bearing |x1 |

23 ASSEMBLY OF THE REAR GEAR CASE

BAG 4

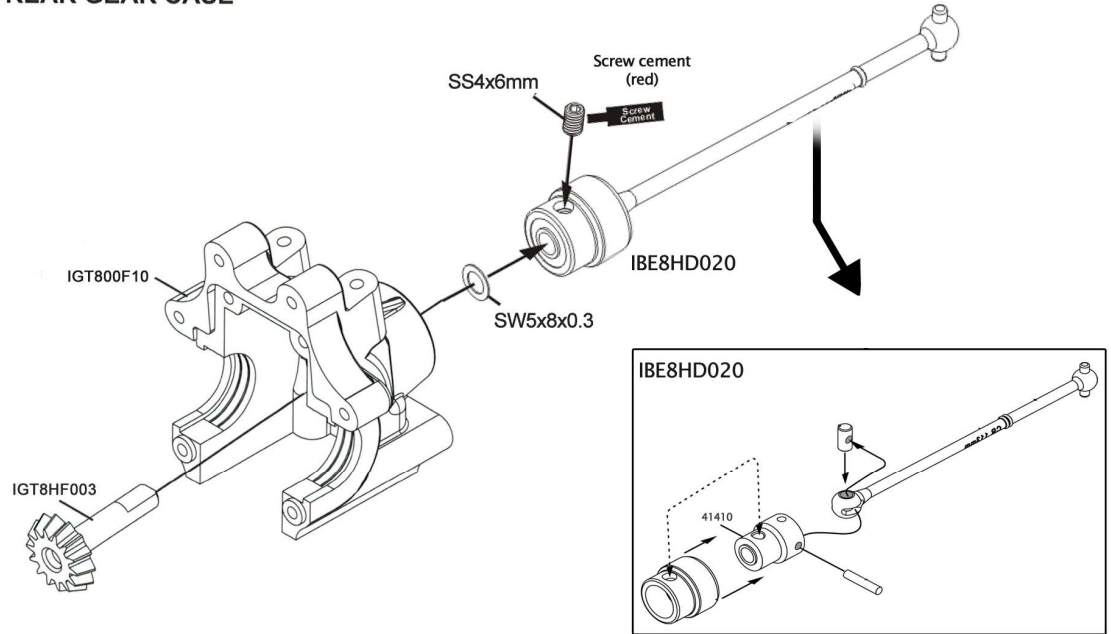

- | | | |
|--|--------------------|---------|
| | SW5x8x0.3mm Washer |x1 |
|--|--------------------|---------|

24 ASSEMBLY OF THE REAR DIFFERENTIAL INTO GEAR CASE

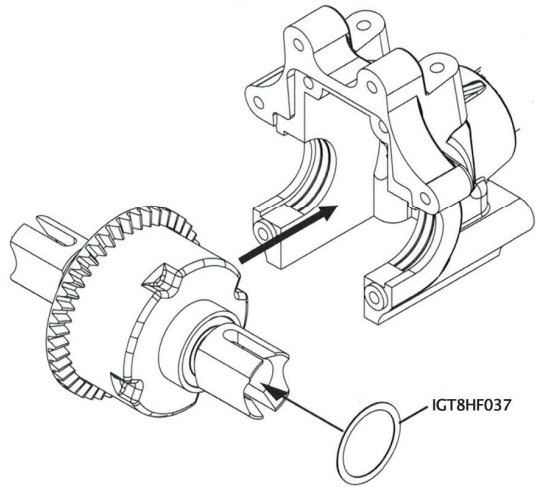
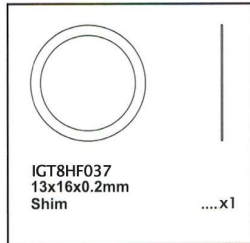

BAG 1

BAG 4

25 ASSEMBLY OF THE REAR GEAR CASE COVER AND LOWER ARM HOLDERS

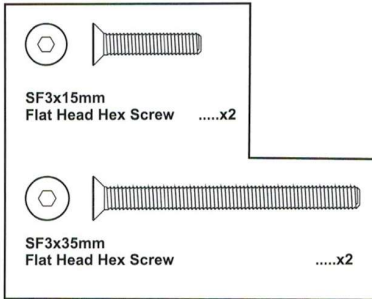

BAG 4

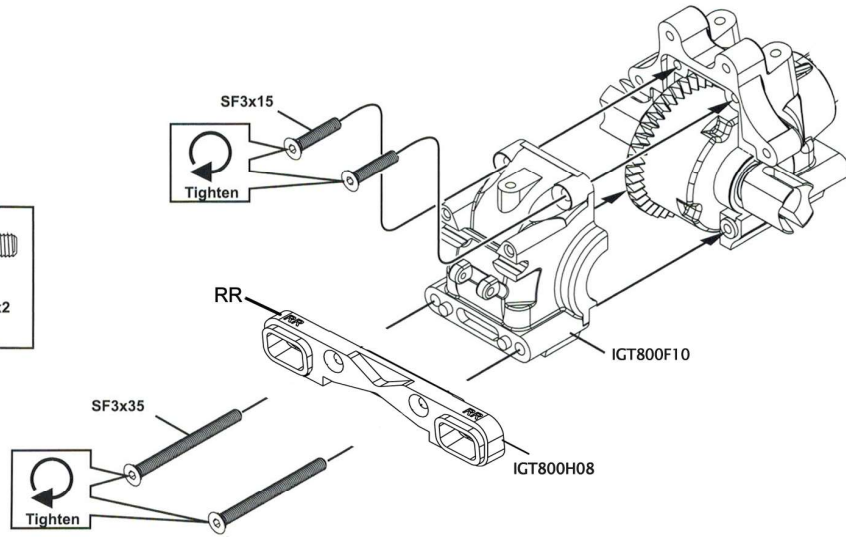

26 ASSEMBLY OF THE REAR BRACE MOUNT

BAG 4

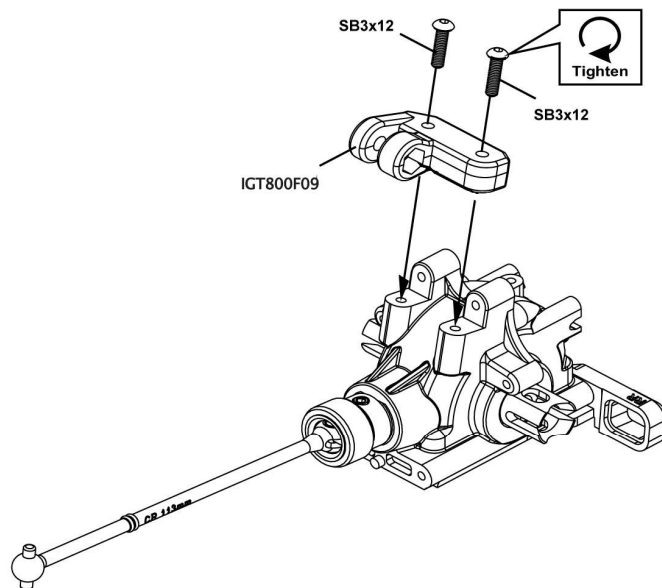

27 ASSEMBLY OF THE REAR SHOCK STAY

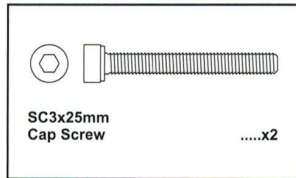
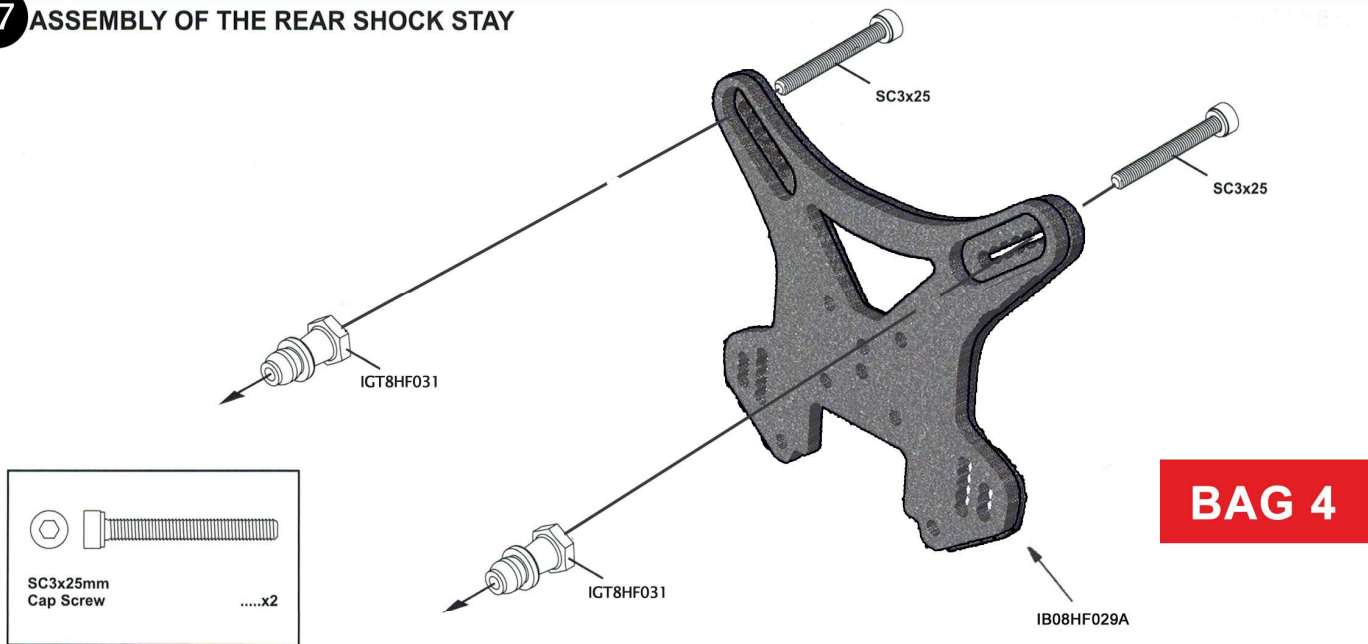

28 ASSEMBLY OF THE REAR SHOCK STAY ONTO REAR GEAR CASE

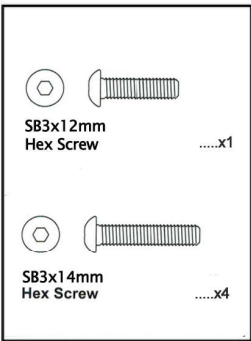
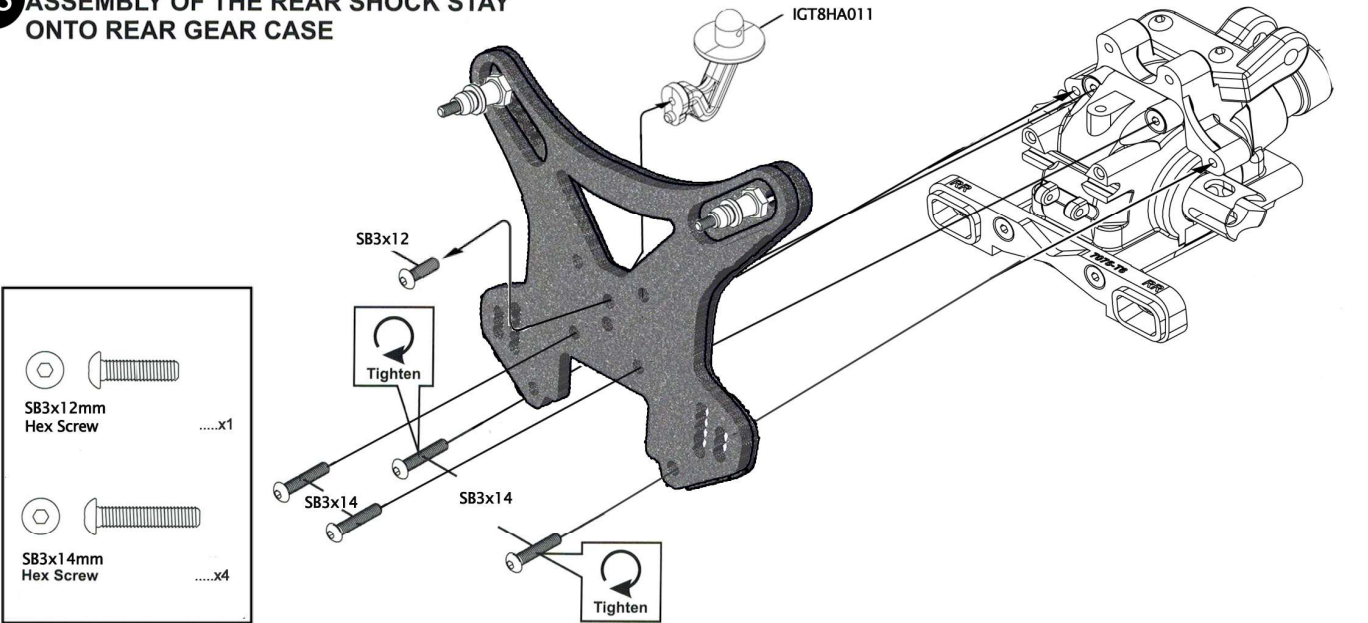

29 ASSEMBLY OF THE REAR LOWER ARMS

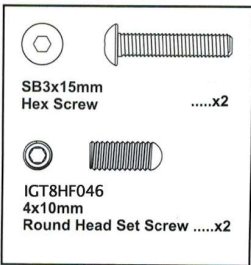
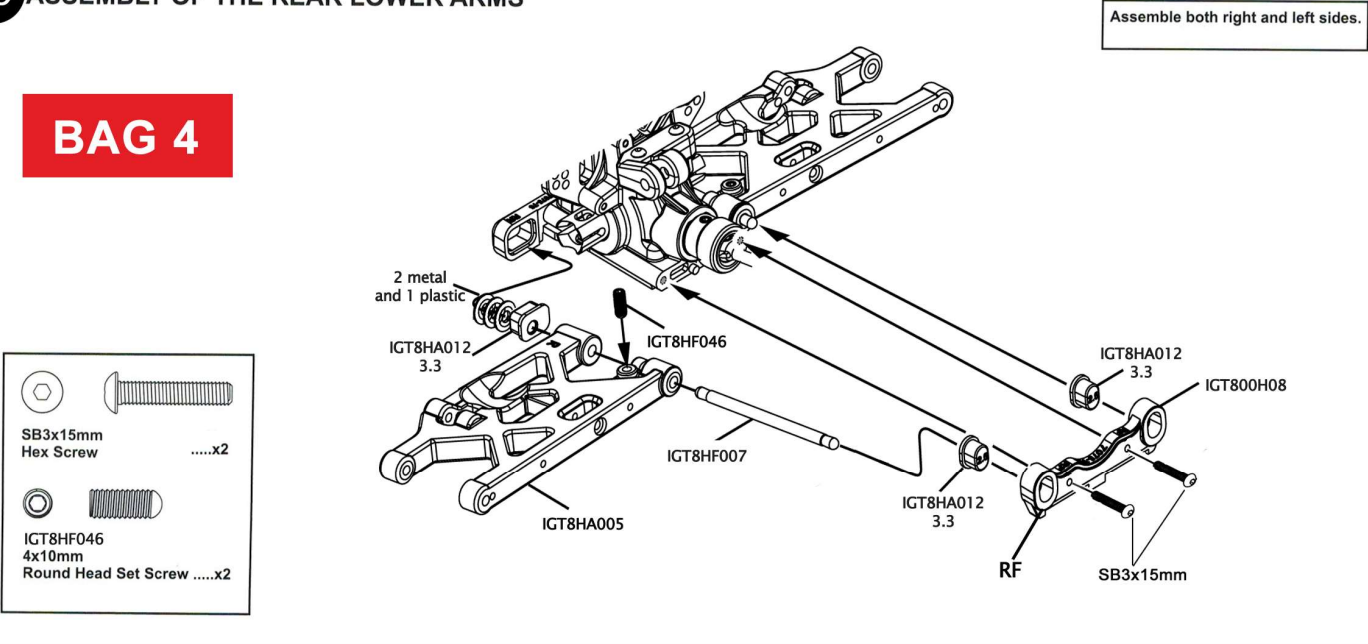

30 ASSEMBLY OF THE REAR STABILIZER

BAG 4

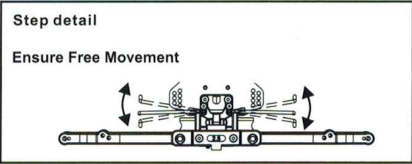
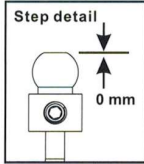

- SB2.5x8mm Hex Screwx2
- SC2x12mm Cap Screwx1
- SB3x18mm Hex Screwx2
- SS3x3mm Set Screwx4

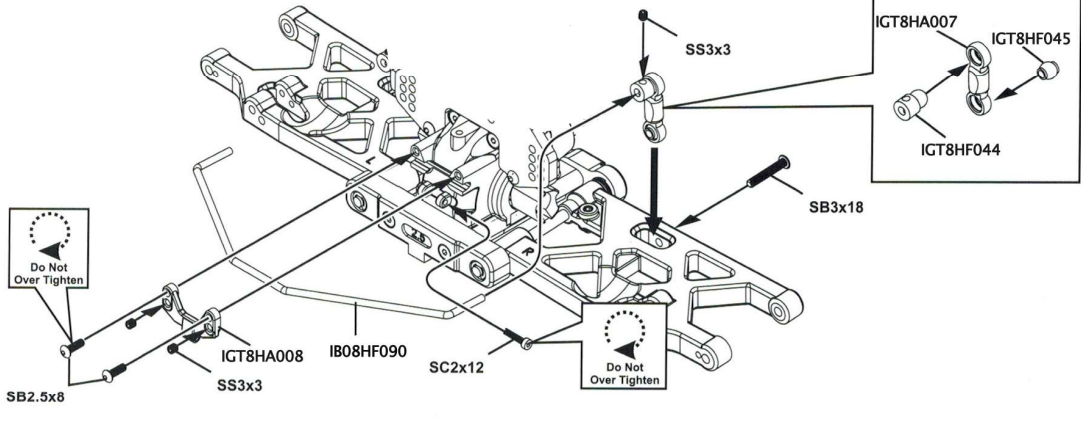

31 ASSEMBLY OF THE REAR WHEEL HUBS

BAG 4

- IGT8HF039 2.5x16.8mm Pinx2
- 4x4mm Set Screwx2

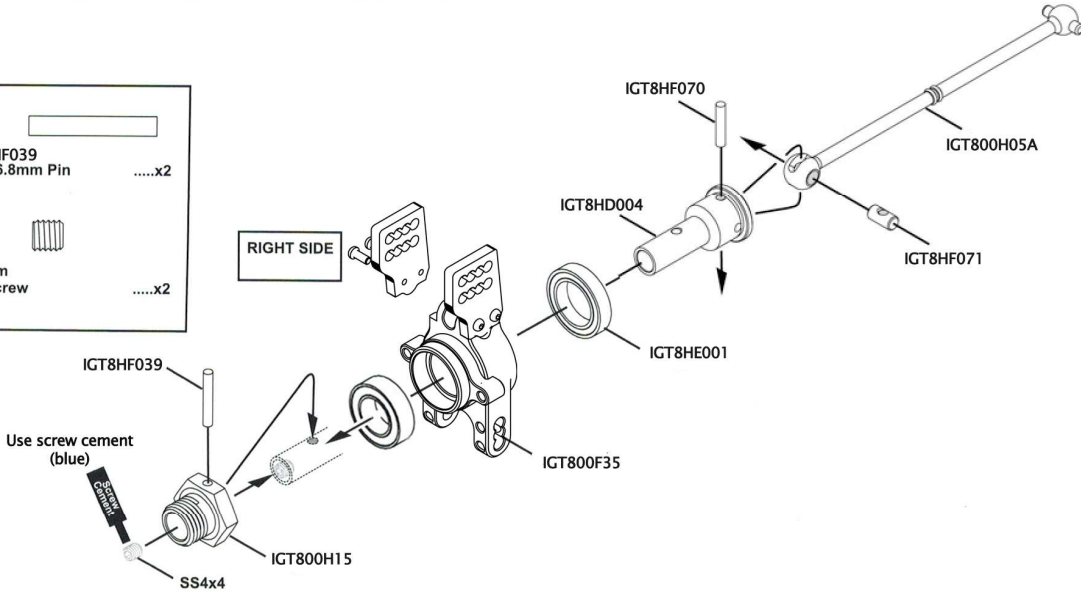

32 ASSEMBLY OF THE REAR SUSPENSION ARMS

Assemble both right and left sides.

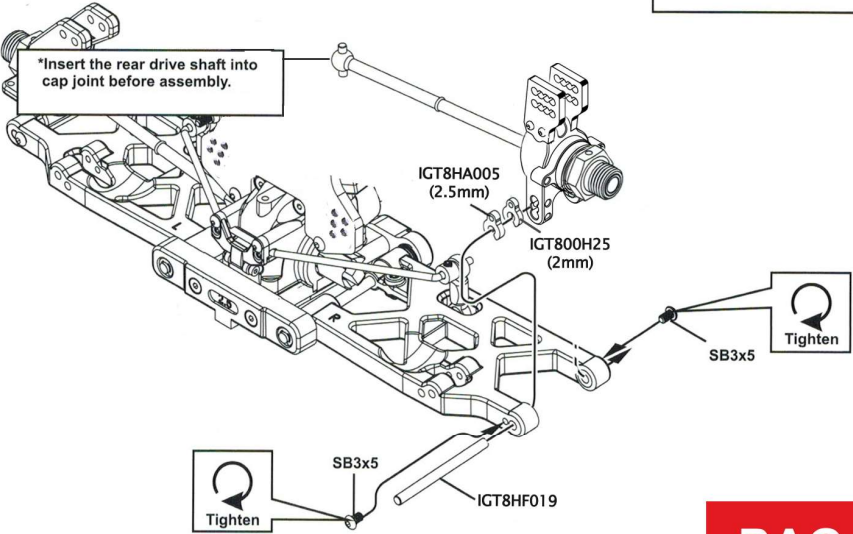
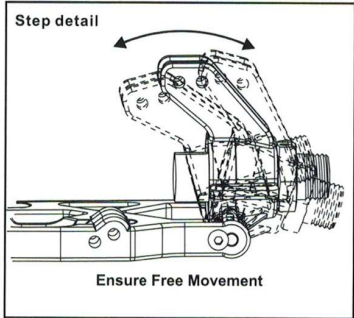

- SB3x5mm Hex Screwx4

BAG 4

33 ASSEMBLY OF THE REAR UPPER ARMS

BAG 4

Assemble both left and right sides.

RIGHT SIDE

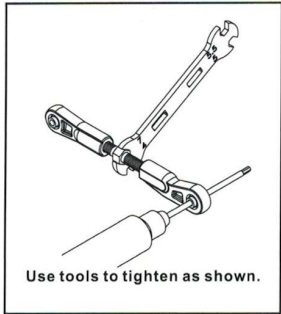
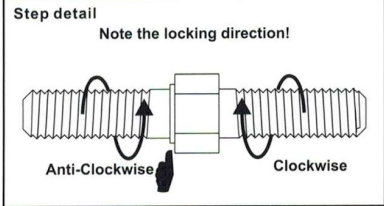
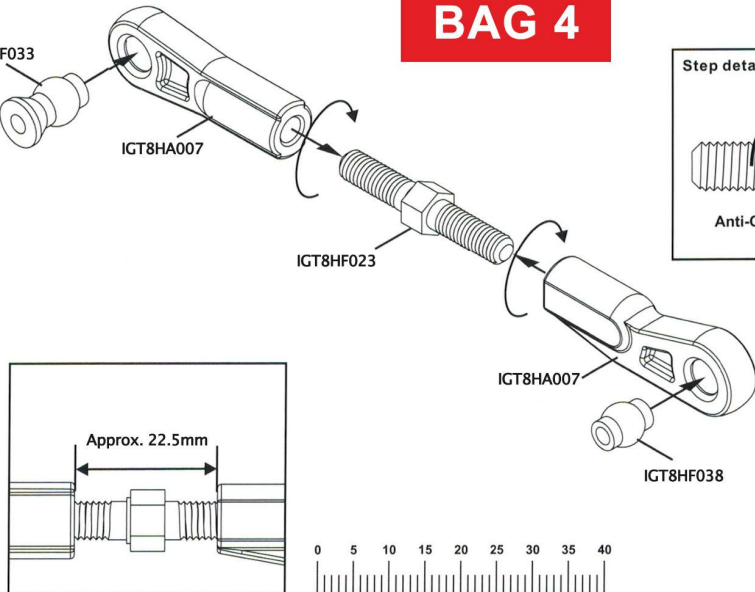
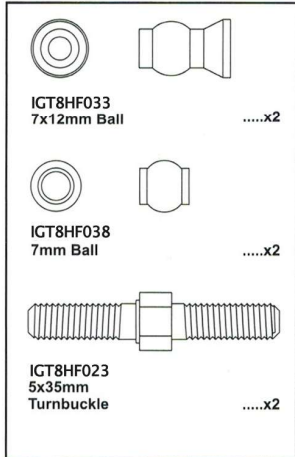

34 ASSEMBLY OF THE REAR UPPER ARMS

BAG 4

Assemble both right and left sides.

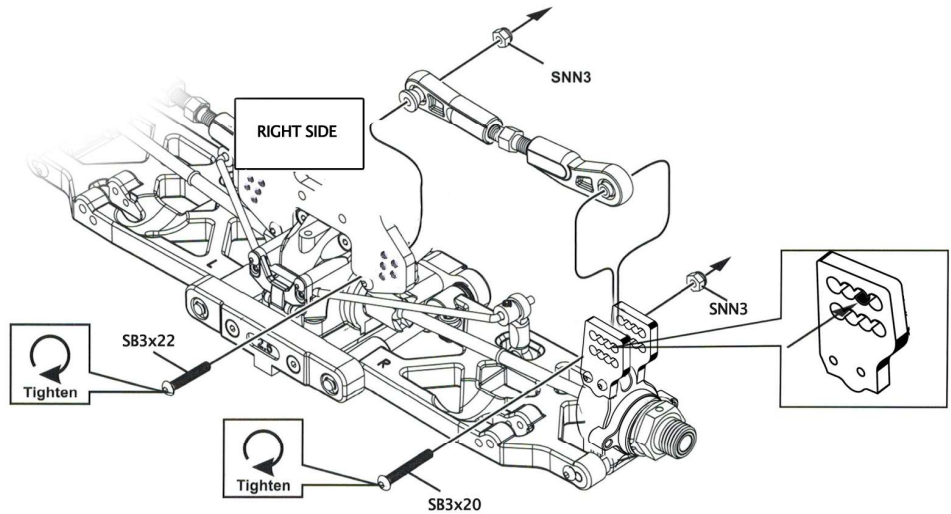
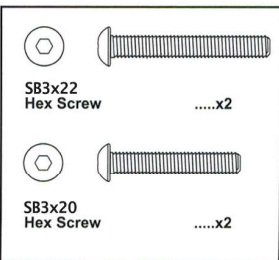

35 ASSEMBLY OF THE REAR CENTER BRACE

BAG 4

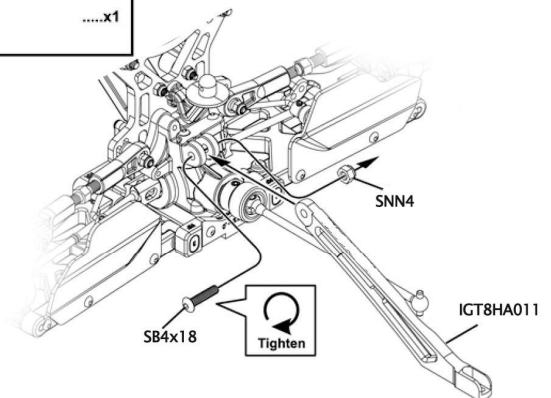
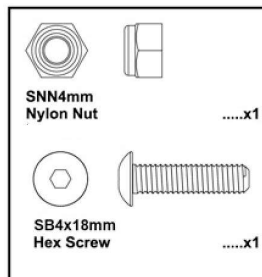
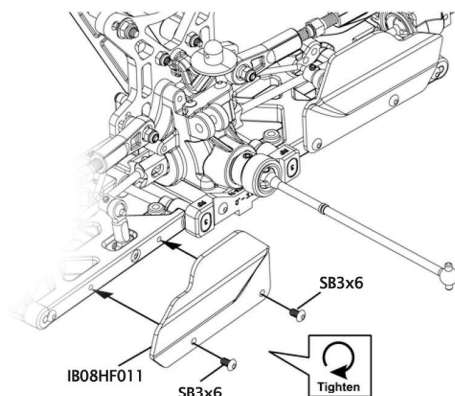
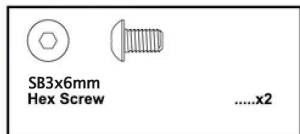



37 ASSEMBLY OF THE WING STAY ONTO SHOCK STAY

	x2
	x2
	x2

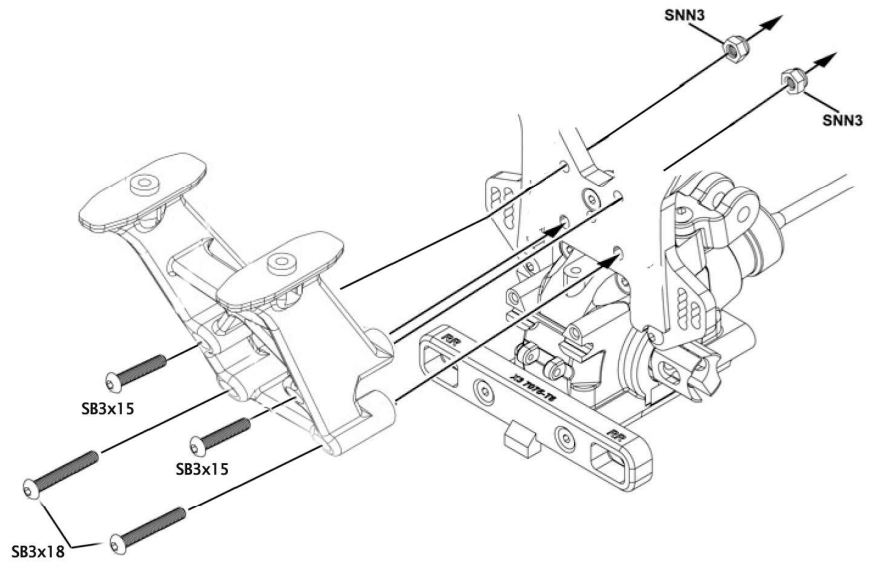

38 ASSEMBLY OF THE STONE GUARD



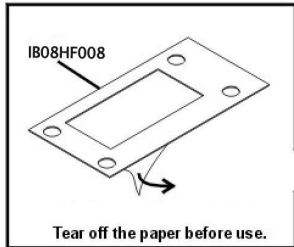

Assemble both right and left sides.

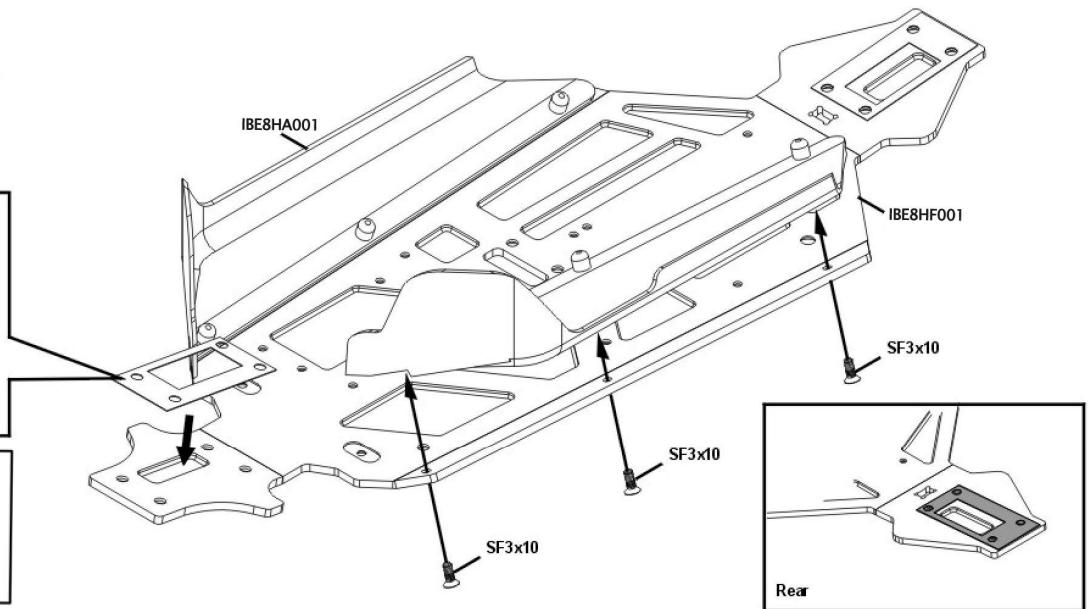

	x10
--	--	----------



39 ASSEMBLY OF THE FRONT GEAR CASE ONTO CHASSIS

-  SF3x10mm Flat Head Hex Screwx2
-  SF4x12mm Flat Head Hex Screwx2
-  SF4x16mm Flat Head Hex Screwx2
-  SNN3mm Nylon Nutx2

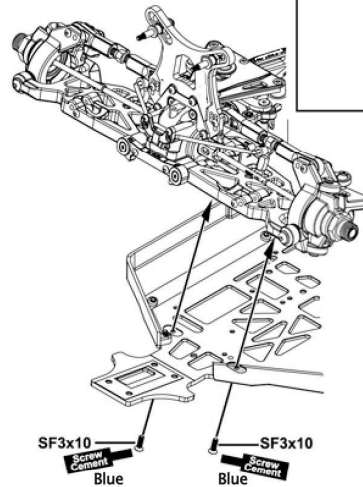
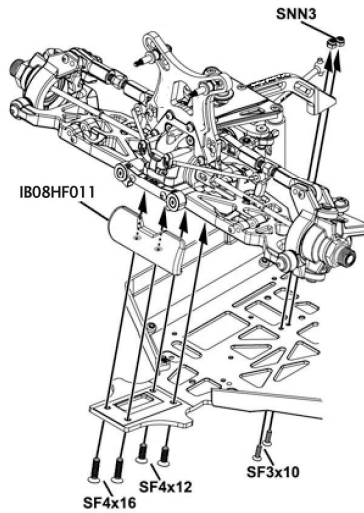



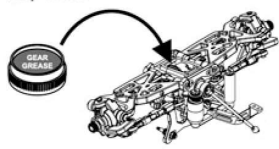

Step detail



Fill the right amount of grease.

40 ASSEMBLY OF THE REAR GEAR CASE ONTO CHASSIS

-  SF3x10mm Flat Head Hex Screwx2
-  SF4x12mm Flat Head Hex Screwx2
-  SF4x16mm Flat Head Hex Screwx2
-  SNN3mm Nylon Nutx2



Step detail

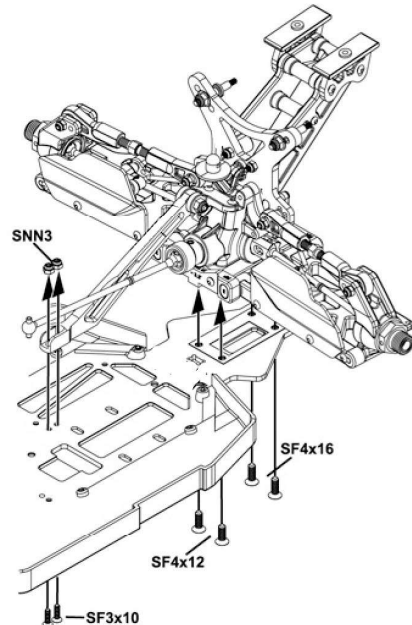

Fill the right amount of grease.



41 ASSEMBLY OF THE CENTER DIFF MOUNT

-  SB3x8mm Hex Screwx4
-  SB3x30mm Hex Screwx2

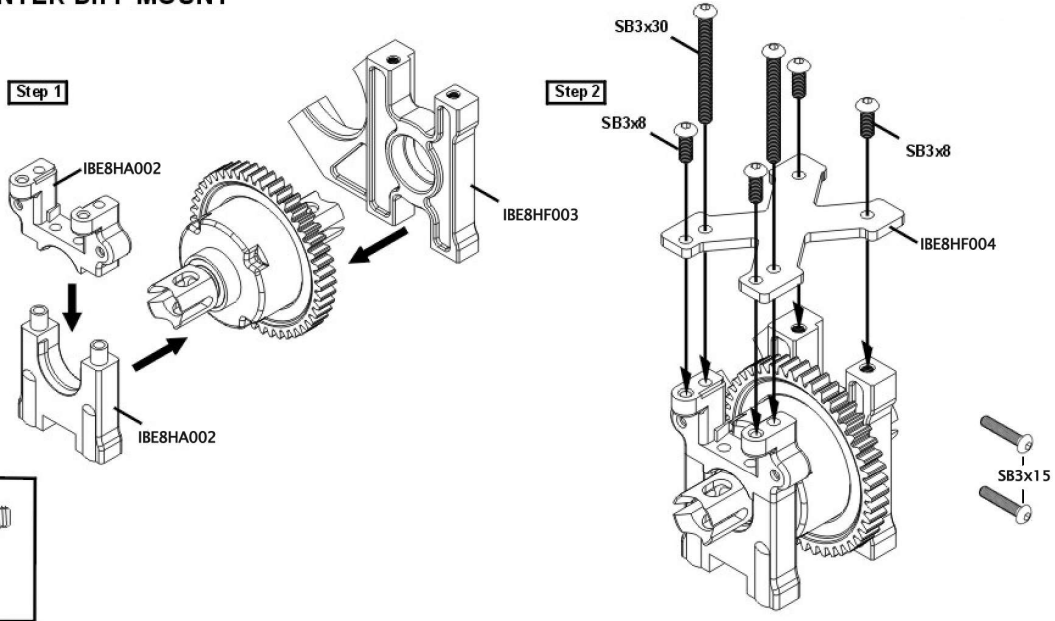

41a ASSEMBLY OF THE MOTOR MOUNT

BAG 5

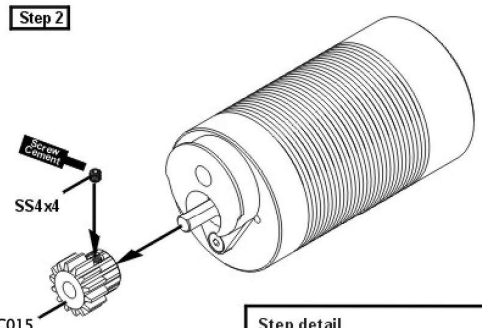
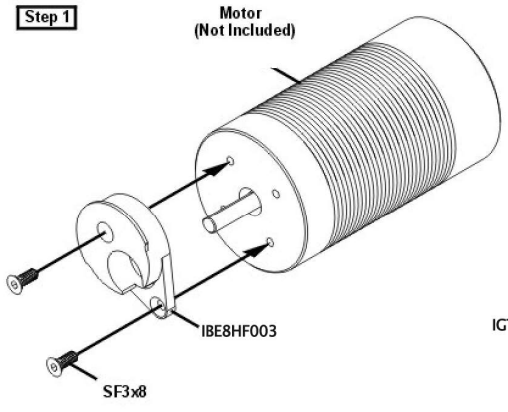

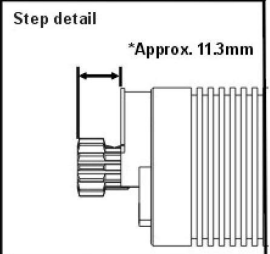

-  SF3x8mm Flat Head Hex Screwx2
-  SS4x4mm Set Screwx1

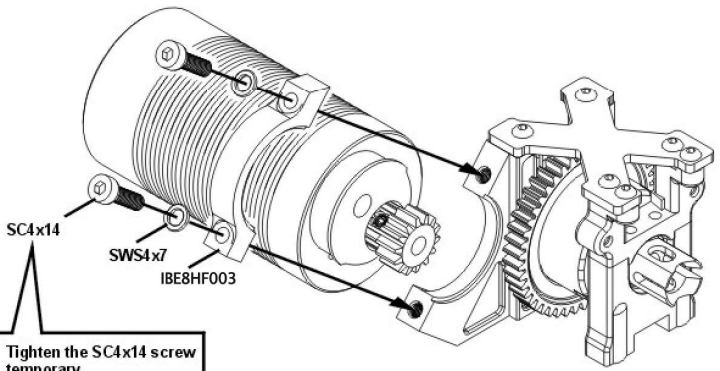

41b ASSEMBLY OF THE MOTOR MOUNT



-  SWS4x7mm Spring Washerx2
-  SC4x14mm Cap Screwx2

Tighten the SC4x14 screw temporary.



42 ASSEMBLY OF THE CENTER DIFF. ONTO CHASSIS

BAG 5

Insert center drive shaft before assembling the center diff. mount.

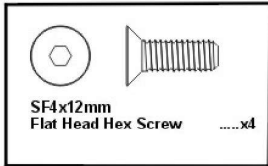
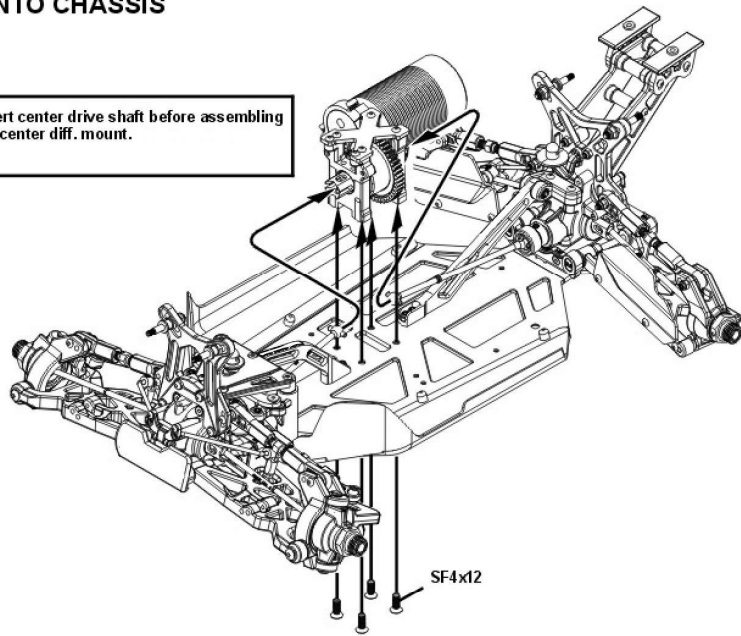

43 ADJUST MOTOR AND SPUR GEAR MAINTENANCE

EXTREMELY IMPORTANT

Step 1

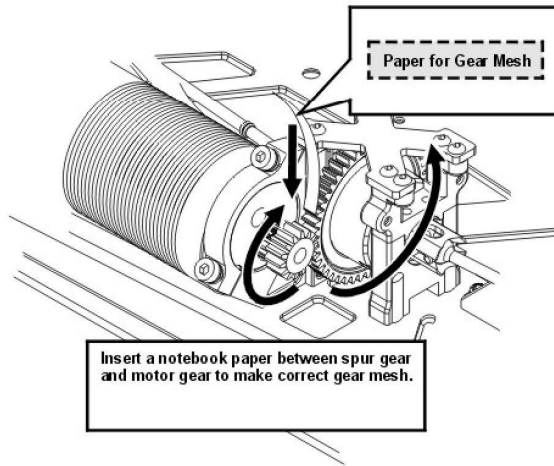

Step 2

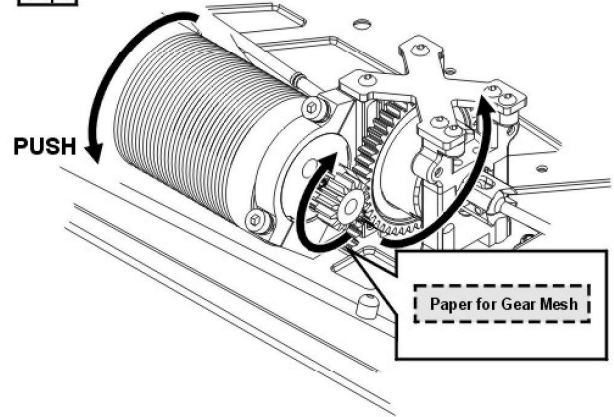

44



45 ADJUST MOTOR AND SPUR GEAR MAINTENANCE

EXTREMELY IMPORTANT

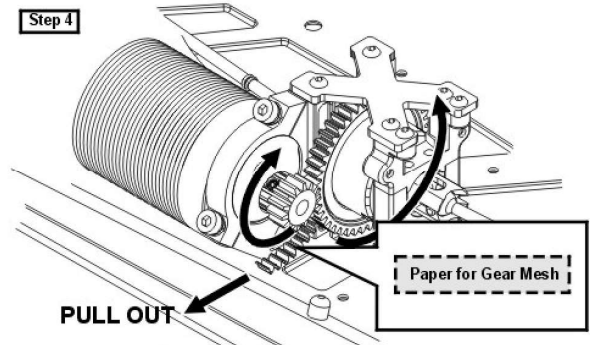
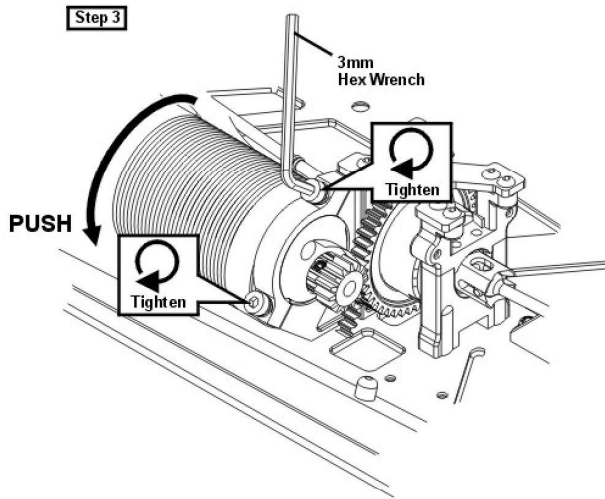

- Adjust the motor mount position to get proper gear mesh.
- To get a perfect gear mesh, place a piece of notebook paper between the gears and tighten the motor mount screws.
- The spur gear may be damaged if the gear mesh is not correct.

46 ASSEMBLY OF THE VELCRO BATTERY STRAPS INTO BATTERY CASE

BAG 6

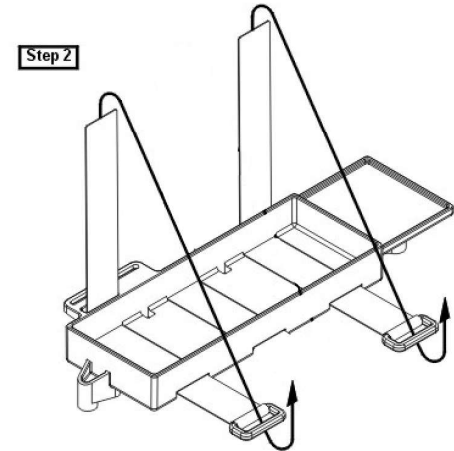
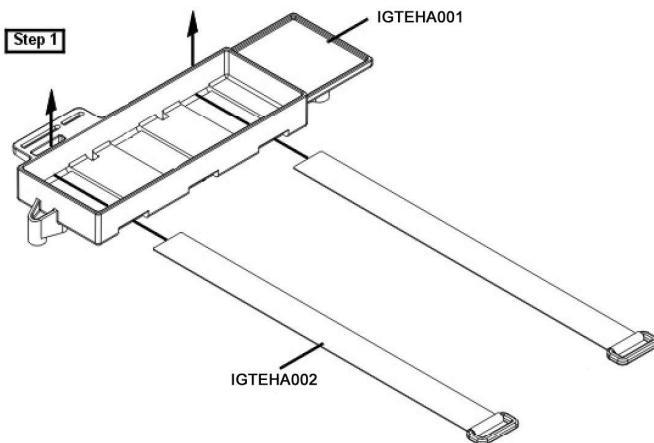

47 ASSEMBLY OF THE ELECTRIC SPEED CONTROL

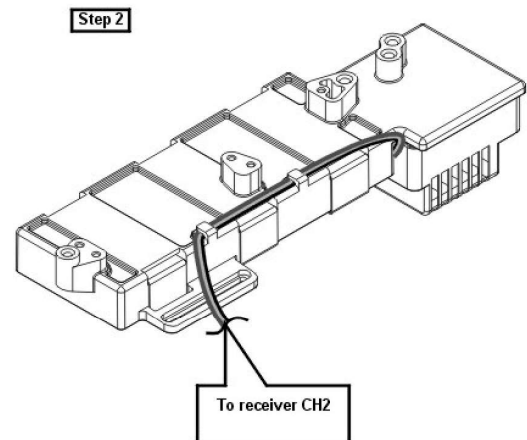
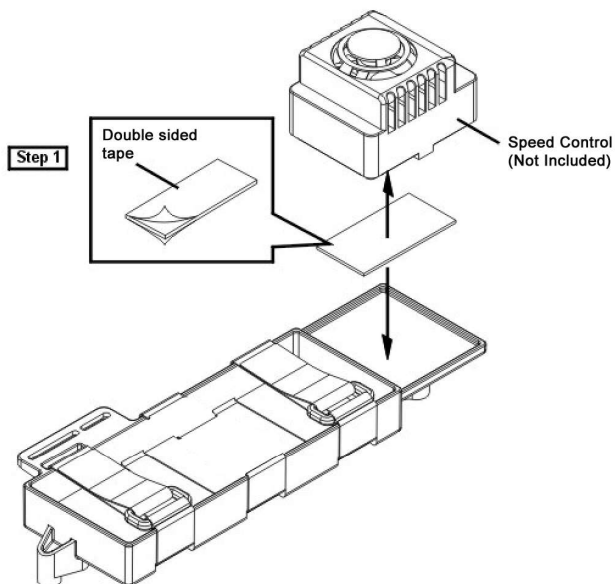

48 ASSEMBLY OF THE STEERING SERVO ONTO RADIO CASE

BAG 6

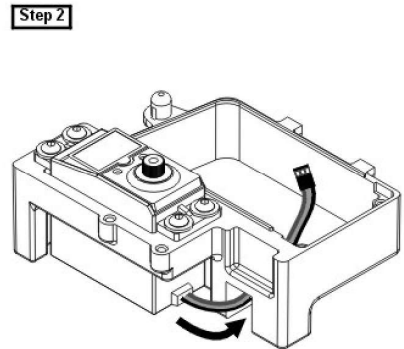
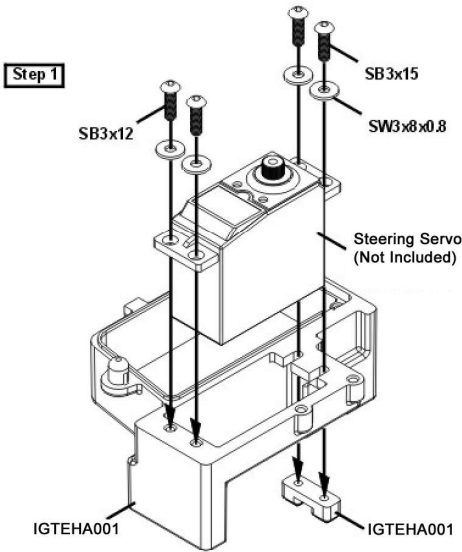
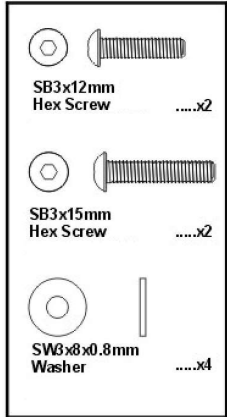

49 ASSEMBLY OF THE BATTERY CASE ONTO CHASSIS

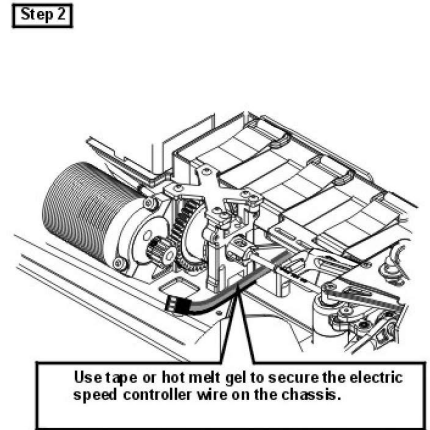
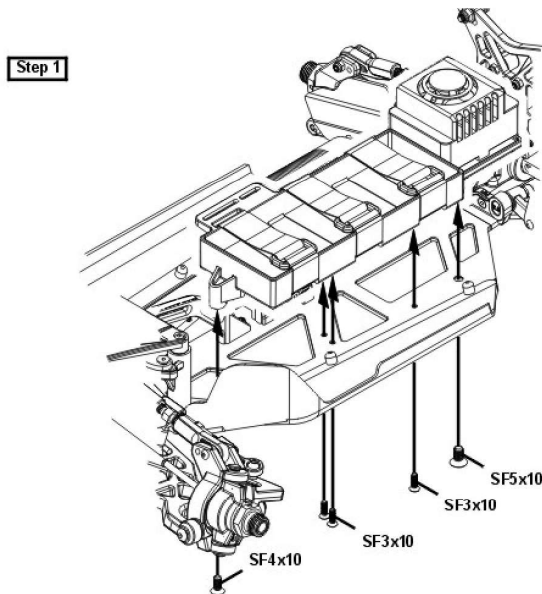
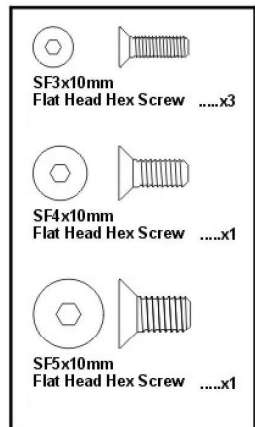

50 ASSEMBLY OF THE RADIO CASE ONTO CHASSIS

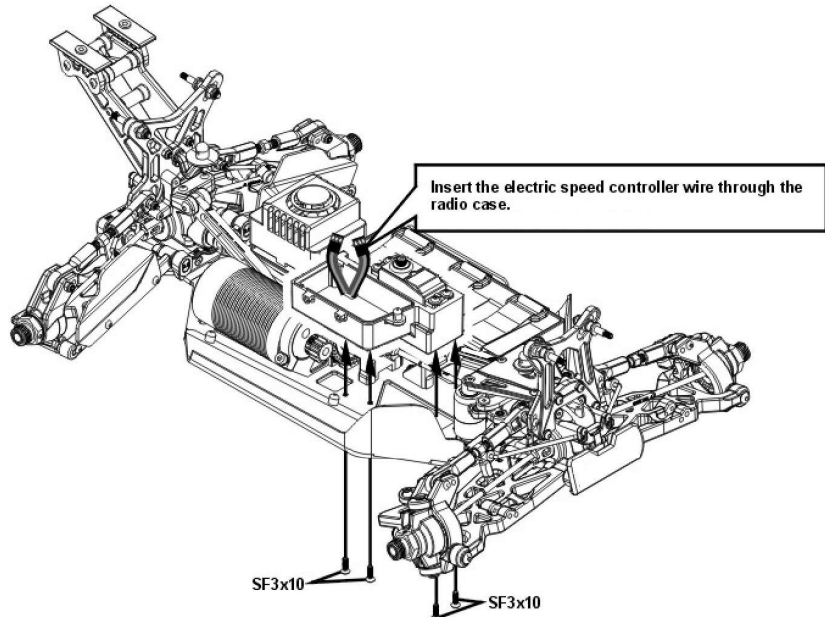

51 ASSEMBLY OF THE RECEIVER INTO RADIO CASE

*Plug in your speed controller wire to CH2 and steering servo wire to CH1 of your receiver.

Receiver (Not Included)

SB3x8

Do not cut or shorten antenna wire.

Step detail

Use a screwdriver to straighten the antenna wire so it is easier to insert into antenna tube.

SB3x8mm Hex Screwx2

52 ASSEMBLY OF THE STEERING ROD

IGT8HF047

IGT8HA007

IGT8HF048

IGT8HA010

IGT8HA007

IGT8HF047

SNN3

SB3x15

Step 2

Step detail

Note the locking direction!

Clockwise

Anti-Clockwise

Use tools to tighten as shown.

Approx. 16mm

BAG 6

SB3x15mm Hex Screwx1

IGT8HF047 6mm Ball and socketx2

SNN3mm Nylon Nutx1

53 ASSEMBLY OF THE STEERING ROD ON STEERING SERVO

Make sure your steering servo at neutral position before assembly.

Neutral

Use the screw provided with your servo.

IGT8HF050

Step detail

SB3x15

SB3x15mm Hex Screwx1

Sanwa/Airtronics	JR	Futaba	HiTech

Choose the right servo horn adapter for your servo.

57 ASSEMBLY OF THE SHOCK ADJUST RING

BAG 9

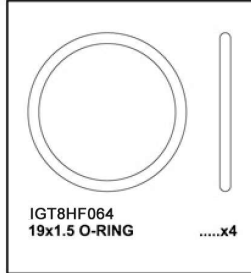

Step 1

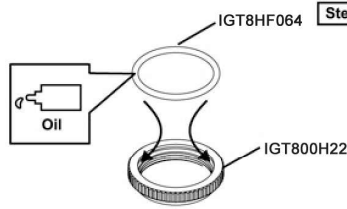

Fit the o-ring into groove before assembly.

Step 2

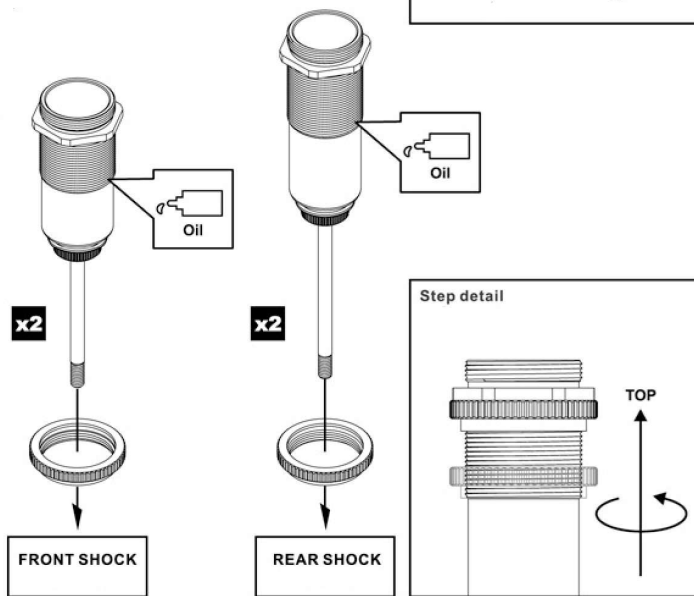

Assemble both left and right sides.

58 ASSEMBLY OF THE SHOCK BALL END

BAG 9

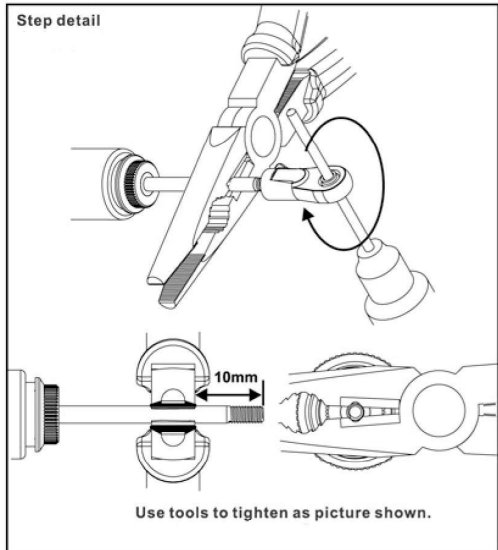
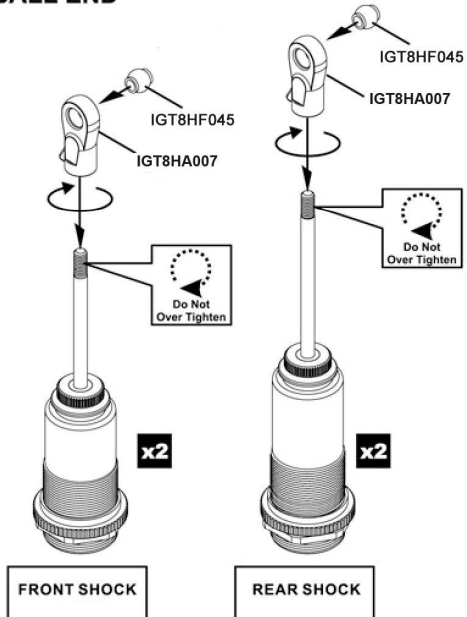
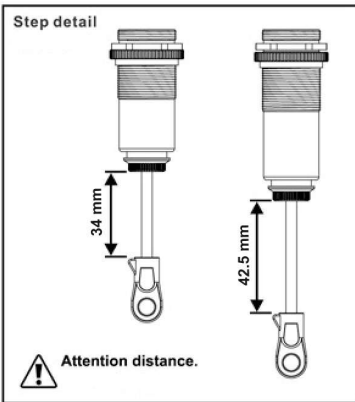

Assemble both left and right sides.

59 SETTING THE SHOCK REBOUND TO 100% (HIGH REBOUND)

BAG 9

FRONT (SHORT) SHOCKS OIL 350 REAR (LONG) SHOCKS OIL 350

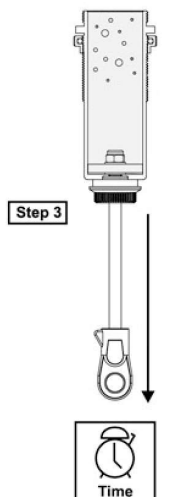
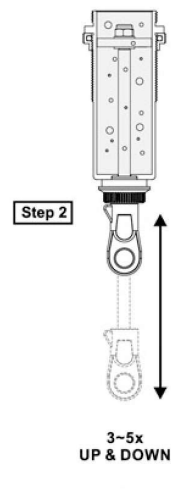
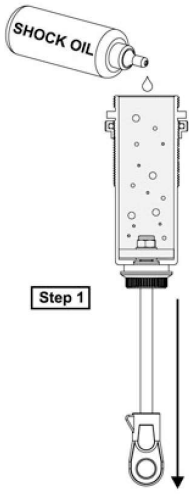

Step 4

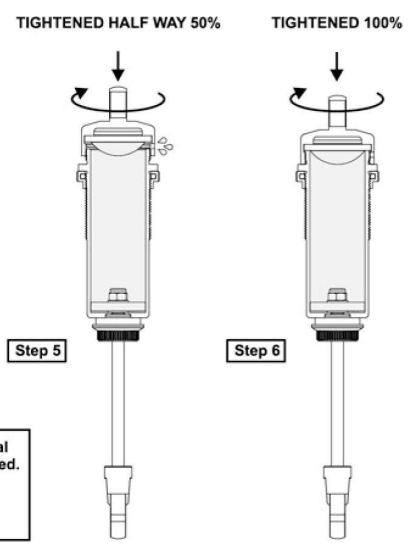
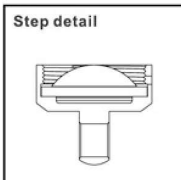
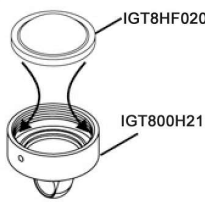

- Leave the filled shock vertically for several minutes with the shock shaft fully extended.
- The remaining air bubbles will release.

Assemble both left and right sides.

60 SETTING THE SHOCK REBOUND TO 50% & 0% (MEDIUM REBOUND & LOW REBOUND)

TIGHTENED HALF WAY 50%

TIGHTENED 100%

TIGHTENED HALF WAY 50%

TIGHTENED 100%

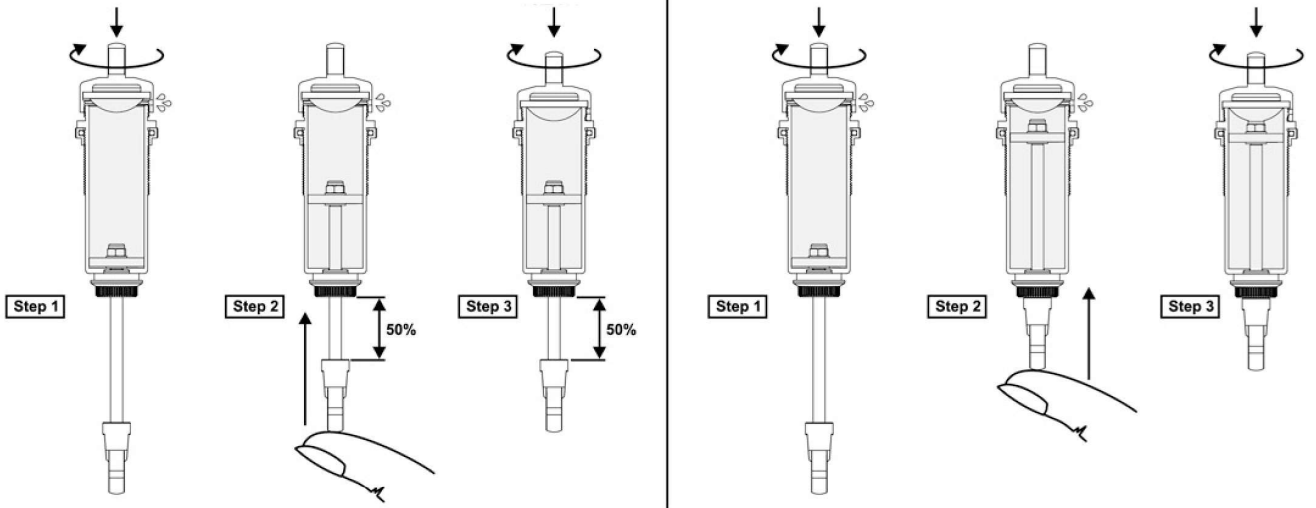

61 ASSEMBLY OF THE SHOCKS SPRING

Step 1

Step 2

Step 3

Step 1

Step 2

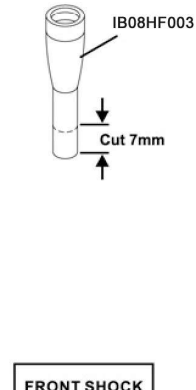

FRONT SHOCK

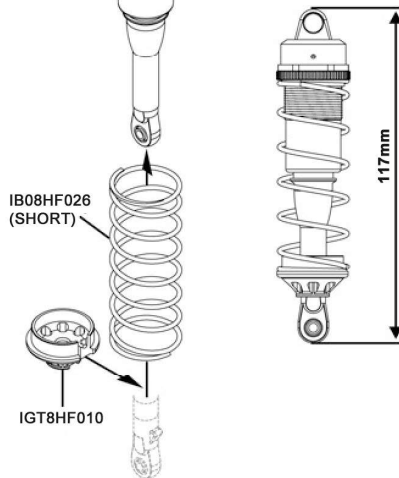

REAR SHOCK

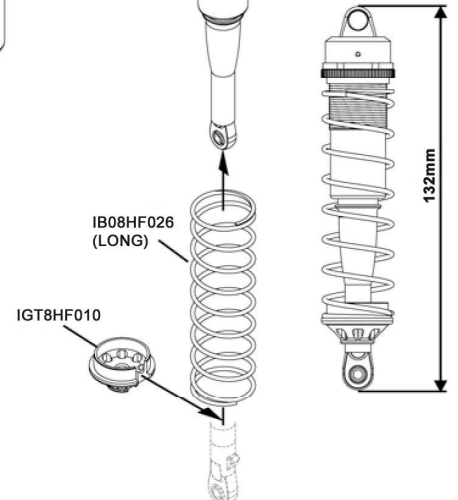

62 ASSEMBLY OF THE SHOCKS INTO THE SHOCK STAY

- SNN3mm Nylon Nutx2
- SW3x8x0.8 Washerx2
- SB3x20mm Hex Screwx1
- 3x20mm Left Thread Hex Screwx1

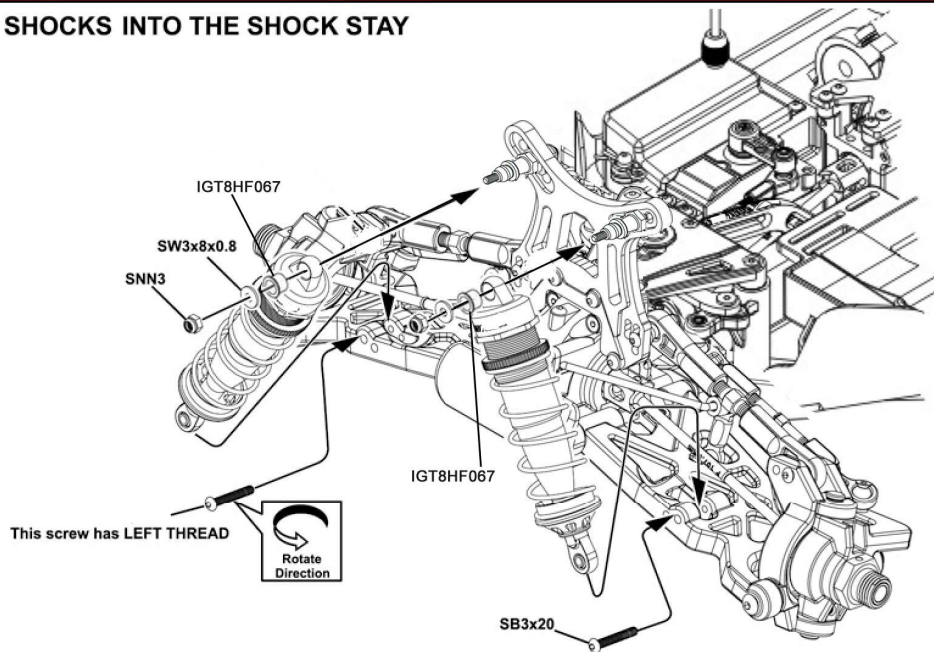

63 ASSEMBLY OF THE WING

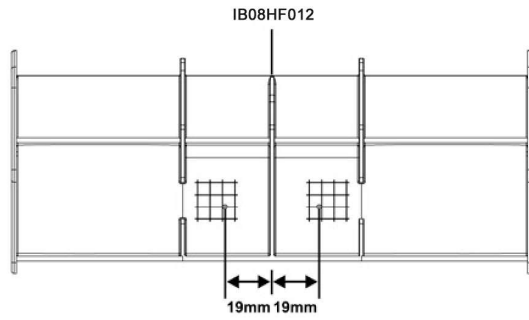

Drill two 7mm holes for mounting.

